

BOILERMATE

INCLUDING SP, SP PRE-PLUMBED AND OV
PRE-PLUMBED

MAINS PRESSURE HOT WATER THERMAL STORE
FOR USE WITH DOMESTIC AND CENTRAL PLANT BOILERS



INSTRUCTION MANUAL
DESIGN, INSTALLATION & SERVICING

ISSUE 02: NOVEMBER 2019

Section	Page
DESIGN	
Introduction	3
Model Selection	5
PRODUCT SPECIFICATION	
OV PP Components	6
OV PP Technical Specification	7
SP Components	8
SP Technical Specification	9
SP PP Components	10
SP PP Technical Specification	11
TRANSPORTATION	
Lifting and Handling	12
INSTALLATION	
Domestic Hot Water	13
Central Heating	18
Store Charging	33
COMMISSIONING	
Commissioning and checks	35
SERVICING AND MAINTENANCE	
Short Parts List	37
Annual Service	38
Changing Components	38
Fault Finding	40
APPENDIX	
Appendix A	46
Appendix B	47
Terms & Conditions	48
Benchmark Checklist	50
Benchmark Service Record	51

The Gledhill BoilerMate range complies with the HWA Specification for hot water only thermal storage products. The principle was developed in conjunction with British Gas. This product is manufactured under an ISO 9001:2008 Quality System audited by BSI.



Benchmark places responsibilities on both manufacturers and installers. The purpose is to ensure that customers are provided with the correct equipment for their needs, that it is installed, commissioned and serviced in accordance with the manufacturers instructions by competent persons and that it meets the requirements of the appropriate Building Regulations. The Benchmark Checklist can be used to demonstrate compliance with Building Regulations and should be provided to the customer for future reference.

Installers are required to carry out installation, commissioning and servicing work in accordance with the Benchmark Code of Practice which is available from the Heating and Hot Water Industry Council who manage and promote the Scheme. Visit www.centralheating.co.uk for more information.

For further information on the HWA Charter Statement, please refer to the HWA website hotwater.org.uk.

Any water distribution system/installation must comply with the relevant recommendations of the current version of the Regulations and British Standards listed below:-

Gas Safety (Installation and use) Regulations 1998
Building Regulations
Water Supply (Water Fittings) Regulations 1999
Manual Handling Operations Regulations

British Standards

BS EN 806:1-5: BS EN 8558:2011
Requirements for Electrical Installations BS7671:2008 and A2:2013 18th Edition

Most new building work will require the relevant building control body to be notified prior to the building work commencing. This will not be required if the work is carried out under a self certification scheme or if the work is not notifiable. Full details of the self certification schemes and work that is not notifiable can be obtained from page 9 of Approved Document G, available from www.planningportal.gov.uk.

A suitably competent trades person must install the BoilerMate and carry out any subsequent maintenance/repairs. The manufacturer's notes must not be taken as overriding statutory obligations.

The Domestic Building Services Compliance Guide 2013 defines, one of the fixed building services, as any part of or controls associated with fixed systems for domestic hot water. All fixed building services, including their controls, should be commissioned by testing and adjustment to ensure that they use no more fuel and power than is reasonable in the circumstances. Where commissioning is required, if it is completed by a person registered with a competent person scheme, the commissioning notice will be supplied by that person, otherwise the person carrying out the work must notify the relevant building control body, that commissioning has taken place in accordance with the Domestic Heating Compliance Guide. The building control body will then be able to issue a completion certificate. This applies to England, for other jurisdictions in the UK, it may be necessary to consult their own building regulations and guidance.

The BoilerMate is not intended for use by persons (including children) with reduced physical, sensory or mental capabilities, or lack of experience or knowledge, unless they have been given supervision or instruction concerning use of the appliance by a person responsible for their safety.

Children should be supervised to ensure that they do not play with the appliance.

The information in this manual is provided to assist generally in the selection of equipment. The responsibility for the selection and specification of the equipment must however remain that of the customer and any Designers or Consultants concerned with the design and installation.

Please Note: We do not therefore accept any responsibility for matters of design, selection or specification or for the effectiveness of an installation containing one of our products unless we have been specifically requested to do so.

All goods are sold subject to our Conditions of Sale, which are set out at the rear of this manual.

In the interest of continuously improving the BoilerMate range, Gledhill Building Products Ltd reserve the right to modify the product without notice, and in these circumstances this document, which is accurate at the time of printing, should be disregarded. It will however be updated as soon as possible after the change has occurred.

The Environment

This product has been manufactured using many recyclable materials, including the approved HCFC/CFC free polyurethane foam insulation. At the end of its useful life, it should be disposed of at a Local Authority Recycling Centre, to maximise the products full environmental benefits.

DESIGN

BoilerMate products are vented cylinders, so there is no requirement for a pressure and temperature relief valve to be fitted to them.

This is a key benefit of a thermal store over an unvented cylinder. This enables greater flexibility of location in the building, as there is no requirement to install discharge pipework with a constant fall to an outside wall, or upgrade the soil and vent pipework to be able to withstand high temperature discharges.

This unit uses minimal power in stand by mode, and can be turned off if required.

All BoilerMates are supplied with an immersion heater 3kW 240v AC, complete with a thermostat set at 75°C and an overheat thermostat set at 90°C, which will require resetting if operated.

The immersion heaters purpose is to provide a backup heat source if the boiler is out of operation. Please note that this back up facility will only provide sufficient input for the domestic hot water requirement.

The heat losses from thermal stores should not be directly compared with heat losses from unvented or vented cylinders because they are treated differently in SAP. This is because the unvented and vented cylinders are tested at 65°C and the thermal store at 75°C.

The feed and expansion tank must be located above the thermal store with the SP and SP PP variants. In the case of the integrated thermal store, BMST-OV PP, the feed and expansion tank water level must also be a minimum of 300mm above the highest radiator.

For hot water only BoilerMate SP and SP PP models, the feed and expansion tank must be above the top of the thermal store.

The maximum working pressure of the thermal store is 1 bar. This means that the feed and expansion tank can be located up to 10 metres above the base of the thermal store.

The OV model has the option of the top up cistern with ballvalve and warning/overflow pipe which can be supplied as an optional extra if required. However, the standard preferred arrangement available for the SP models are for the cistern to be manually filled from a temporary hose connection fitted with a double check valve.

The cistern must not be fitted more than 10 metres above the BoilerMate CP appliance itself.

DESIGN

BoilerMate OV PP

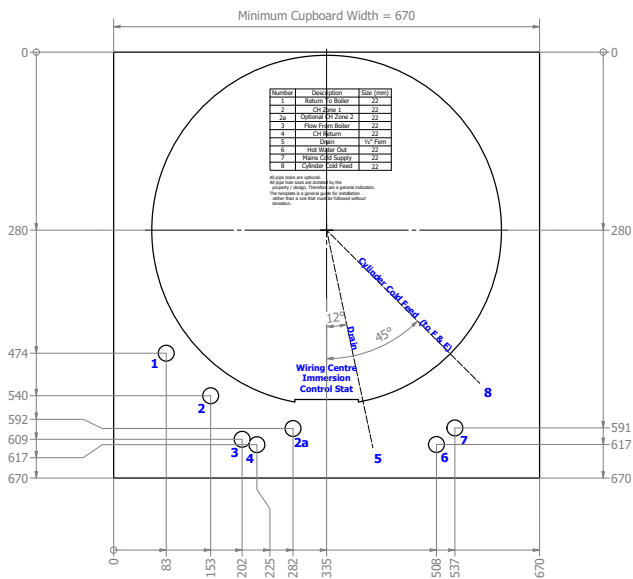

BoilerMate SP

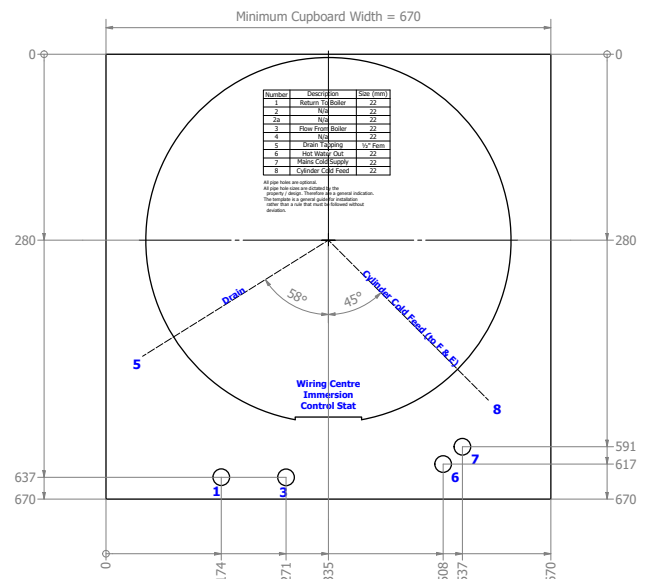

BoilerMate SP PP

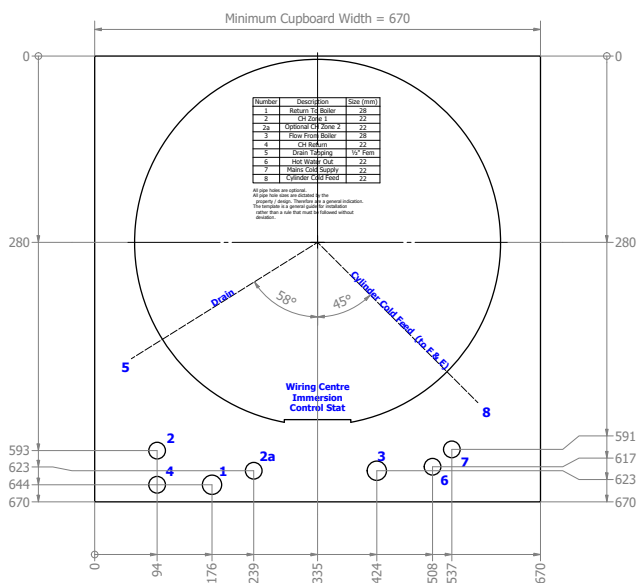

All measurements shown are in millimetres.

Model Selection Guide BoilerMate				
Dwelling Type				
Bedroom	1-2	2-3	2-3	2-4
Bathroom	1 or	1	1	2
En-suite shower rooms	1	1	2	1
Model size required	150	150	180	210

Notes:-

1. Plastic top up cistern is available as an optional kit, and is supplied separately.
2. A minimum of 40°C temperature rise is achieved at 12.6 litres/min flow rate and assume that recommended pressures and adequate flow are available at the appliance. The actual flow rate from the appliance is automatically regulated to a maximum of 15 litres/min.
3. The domestic hot water temperature is not user adjustable.

SELECTION

The BoilerMate OV is an integrated thermal store. It is intended to be used in conjunction with an open vented heat only boiler. The boiler should be plumbed directly to the thermal store. The boiler's purpose is to keep the thermal store hot.

The central heating is intended to be plumbed directly to the thermal store, with the central heating demand being controlled by a timer and room thermostat. The boiler itself is controlled by the store thermostat.

Domestic hot water is generated instantaneously by the BoilerMate domestic hot water assembly. It is supplied to the taps at mains pressure and at 55°C.

Please see the drawing below for connections, location size and type.

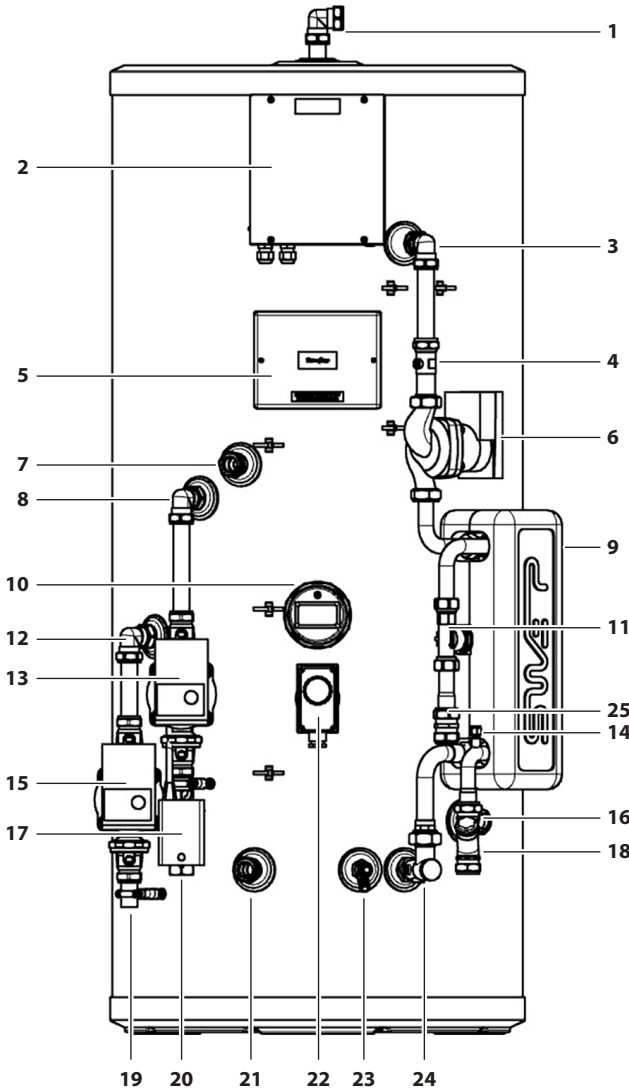

Standard Equipment

The standard configuration of the BoilerMate OV Pre-Plumbed is shown opposite. It is supplied with the following factory fitted equipment:-

- 1 90 degree elbow - vent (22mm compression)
- 2 Domestic hot water PCB box
- 3 Compression elbow (22mm)
- 4 Straight isolator (22mm to FF3/4")
- 5 System wiring panel
- 6 Domestic hot water pump (PWM2)
- 7 Boiler flow (22mm compression)
- 8 Compression elbow (22mm)
- 9 Domestic hot water PHE (insulated) 24 plate
- 10 3kW immersion heater (backup)
- 11 Flow sensor and hot water sensor
- 12 Compression elbow (22mm)
- 13 Central heating pump (including isolation valves)
- 14 Cold water sensor
- 15 Boiler pump (including isolation valves)
- 16 Cold feed (22mm compression)
- 17 Central heating zone valve (22mm)
- 18 In-line strainer/flow regulator (22mm compression) mains cold water in
- 19 Boiler return
- 20 Central heating flow
- 21 Central heating return (22mm)
- 22 Store control thermostat
- 23 Drain valve
- 24 Bent isolator - CV fitted (22mm to FF3/4")
- 25 Hot water outlet (22mm compression)

Optional Equipment Kits For BMST-OVPP

- 1 Open vented header tank kit (BCK001)
- 2 Switch Back up conversion 6kW to 3kW kit (BCK003)
- 3 Timer kit (BCK004)
- 4 Second Heating Zone kit (BCK006)
- 5 Pump over run kit (BCK007)
- 6 DHW scale prevention kit (BCK008)

Please note that the copper pipework connected to the Boiler Return (19) is only for support in transit. Replace with the correct length to suit the installation requirement.

Full details of the optional kits, available at the time of order, on page 34.

SELECTION

Technical Specification BoilerMate OV Pre-Plumbed				
Product Stock Code		BMSTOV150PP	BMSTOV180PP	BMSTOV210PP
Energy efficiency class		C	C	C
Heat loss	watts	47	55	62
	kWh/24hr	1.48	1.78	2.08
Height	mm	1118	1306	1494
Diameter	mm	550	550	550
Min cupboard height ¹	mm	1668	1856	2044
Min cupboard width	mm	670	670	670
Min cupboard depth	mm	670	670	670
Weight (empty)	kg	38	42	50
Weight (full)	kg	189	222	261
Thermal store volume	litres	151	181	211
DHW dedicated volume	litres	64	77	90
DHW space heating volume	litres	85	103	120
Average reheat power ²	kW	24	26	26
Average reheat time ³	mins	16	19	20
Maximum DHW pressure	bar	5	5	5
DHW performance (No space heating)				
Test flow rate	litres/min	12.6	12.6	12.6
Test volume above 40°C	litres	138	154	196
Average DHW temperature	°C	54	53	52
Average temperature rise	°C	44	42	44
Thermal store test temperature	°C	75	75	75
DHW performance (Space heating)				
Test flow rate	litres/min	12.6	12.6	12.6
Test volume above 40°C	litres	78	103	137
Average DHW temperature	°C	50	49	51
Average temperature rise	°C	40	37	42
Thermal store test temperature	°C	61	63	63

Notes:-

1. The height stated is to the top of the unit plus 550mm, which should allow for a 25mm thick shelf/board and room for servicing. This will need to be increased by 125mm if the automatic fill method is chosen.
2. OV model heated by a 30kW boiler at 15 l/m.
3. Full thermal store volume reheated from 35°C to 75°C.
4. Please refer to page 5 for the minimum cupboard space requirement. This can be reduced by approximately 35mm if the insulation is removed from the plate heat exchanger.

SELECTION

The BoilerMate SP is a hot water only thermal store. It is intended to be used in conjunction with a sealed primary system. This is generally expected to be a system boiler; however this product can also be in a central plant or district heating system. Please check the table opposite for the maximum pressures.

Heat energy is input into the store via the store plate heat exchanger, store pump and associated pipework which is fitted to the product. The installer must supply all the other necessary components to feed the boiler side of the store plate heat exchanger.

Domestic hot water is generated instantaneously by the BoilerMate domestic hot water assembly. It is supplied to the taps at mains pressure and at 55°C. See the domestic hot water installation section for details.

Please see the drawing below for connections, location size and type.

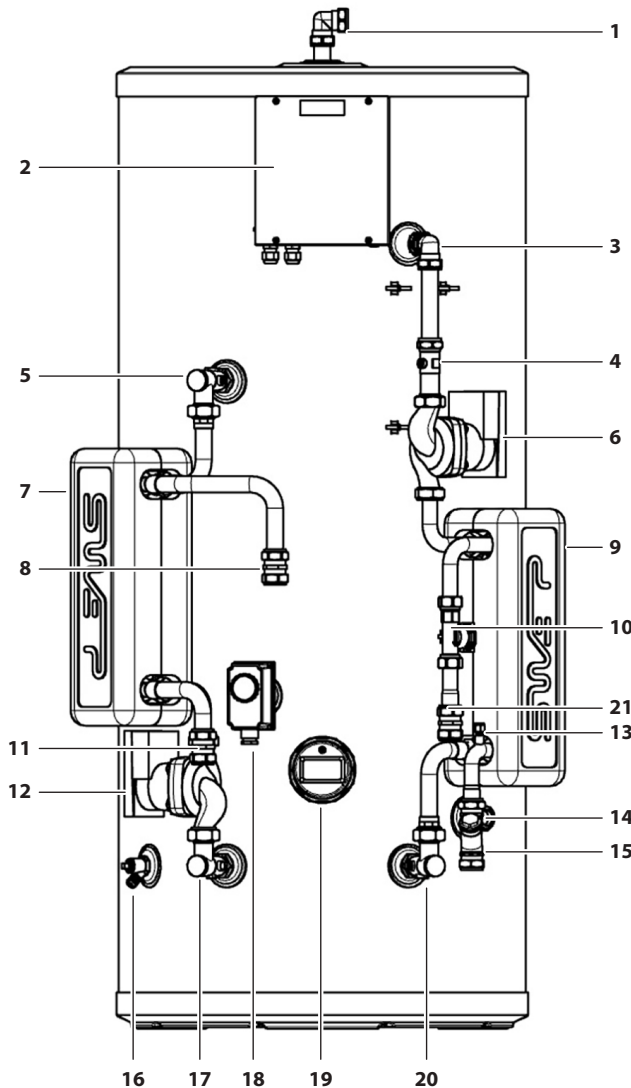

Standard Equipment

The standard configuration of the BoilerMate SP is shown opposite. It is supplied with the following factory fitted equipment:-

- 1 90 degree elbow - vent (22mm compression)
- 2 Domestic hot water PCB box
- 3 Compression elbow (22mm)
- 4 Straight isolator (22mm to FF3/4")
- 5 Bent isolator - CV fitted (22mm to FF3/4")
- 6 Domestic hot water pump (PWM2)
- 7 Store PHE (insulated) 24 plate
- 8 Boiler flow (22mm compression)
- 9 Domestic hot water PHE (insulated) 24 plate
- 10 Flow sensor and hot water sensor
- 11 Boiler return (22mm compression)
- 12 Store pump
- 13 Cold water sensor
- 14 Cold feed (22mm compression)
- 15 Inline strainer/flow regulator (22mm compression) mains cold water in
- 16 Drain valve
- 17 Bent isolator (22mm to FF3/4")
- 18 Store control thermostat
- 19 3kW immersion heater (backup)
- 20 Bent isolator - CV fitted (22mm to FF3/4")
- 21 Hot water outlet (22mm compression)

Optional Equipment Kits For BMST-SP

1. Sealed primary header tank kit (BCK002)
2. Switch Back up conversion 6kW to 3kW kit (BCK003)
3. Timer kit (BCK004)
4. Sealed system ROBOKIT (BCK005)
5. Second Heating Zone kit (BCK006)
6. Pump over run kit (BCK007)
7. DHW scale prevention kit (BCK008)

Full details of the optional kits, available at the time of order, on page 34.

SELECTION

Technical Specification BoilerMate SP				
Product Stock Code		BMSTSP150	BMSTSP180	BMSTSP210
Energy efficiency class		C	C	C
Heat loss	watts	47	55	62
	kWh/24hr	1.48	1.78	2.08
Height	mm	1118	1306	1494
Diameter	mm	550	550	550
Min cupboard height ¹	mm	1668	1856	2044
Min cupboard width	mm	670	670	670
Min cupboard depth	mm	670	670	670
Weight (empty)	kg	38	42	50
Weight (full)	kg	189	223	262
Thermal store volume	litres	151	181	211
DHW dedicated volume	litres	151	181	211
DHW space heating volume	litres			
Average reheat power ²	kW	21	19	19
Average reheat time ³	mins	18	26	29
Maximum DHW pressure	bar	5	5	5
DHW performance				
Test flow rate	litres/min	12.6	12.6	12.6
Test volume above 40°C	litres	138	154	196
Average DHW temperature	°C	54	53	55
Average temperature rise	°C	41	41	43
Thermal store test temperature	°C	75	75	75

Notes:-

1. The height stated is to the top of the unit plus 550mm, which should allow for a 25mm thick shelf/board and room for servicing. This will need to be increased by 125mm if the automatic fill method is chosen.
2. SP model heated from a heat source at 82.5°C at 16 l/m.
3. Full thermal store volume reheated from 35°C to 75°C.
4. Please refer to page 5 for the minimum cupboard space requirement. This can be reduced by approximately 70mm if the insulation is removed from the plate heat exchangers.

SELECTION

The BoilerMate SP Pre-Plumbed is a hot water only thermal store. It is intended to be used in conjunction with a sealed primary system. This is generally expected to be a system boiler; however this product can also be in a central plant or district heating system. Please check the table opposite for the maximum pressures.

Heat energy is input into the store via the store plate heat exchanger, store pump and associated pipework which is fitted to the product. The installer must supply all the other necessary components to feed the boiler side of the store plate heat exchanger.

Domestic hot water is generated instantaneously by the BoilerMate domestic hot water assembly. It is supplied to the taps at mains pressure and at 55°C. See the domestic hot water installation section for details.

Please see the drawing below for connections, location size and type.

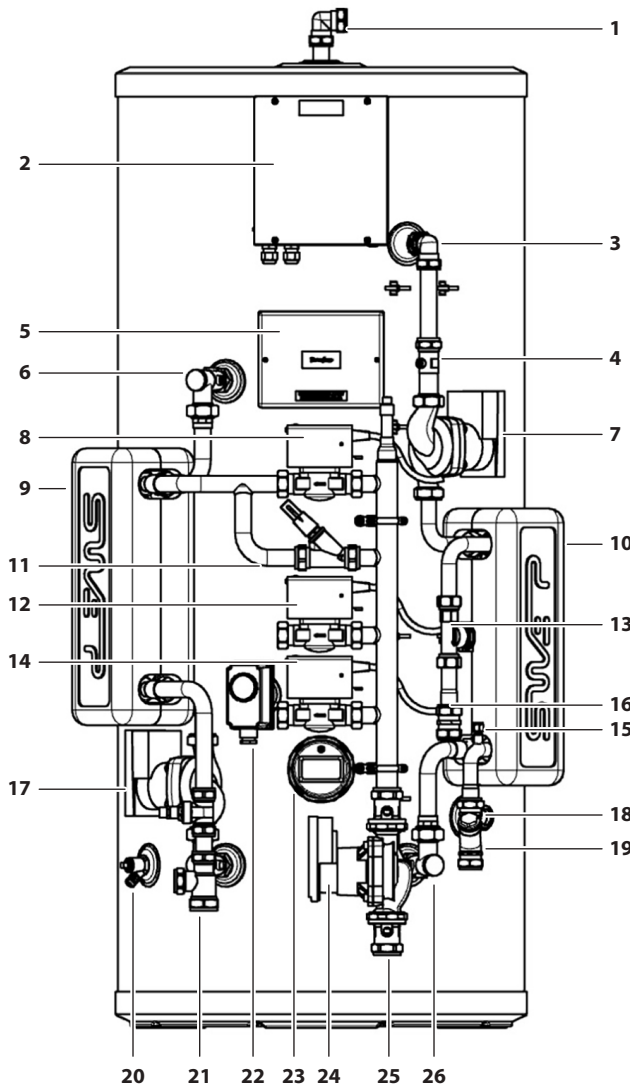

Standard Equipment

The standard configuration of the BoilerMate SP Pre-Plumbed is shown opposite. It is supplied with the following factory fitted equipment:-

- 1 90 degree elbow - vent (22mm compression)
- 2 Domestic hot water PCB box
- 3 Compression elbow (22mm)
- 4 Straight isolator (22mm to FF3/4")
- 5 System wiring panel
- 6 Bent isolator - CV fitted (22mm to FF3/4")
- 7 Domestic hot water pump (PWM2)
- 8 Boiler zone valve for store charging
- 9 Store PHE (insulated) 24 plate
- 10 Domestic hot water PHE (insulated) 24 plate
- 11 Auto bypass valve
- 12 Central heating zone 1
- 13 Flow sensor and hot water sensor
- 14 Central heating zone 2
- 15 Cold water sensor
- 16 Hot water outlet (22mm compression)
- 17 Store pump
- 18 Cold feed (22mm compression)
- 19 Inline strainer/flow regulator (22mm compression) mains cold water in
- 20 Drain valve
- 21 Central heating boiler return
- 22 Store control thermostat
- 23 3kW immersion heater (backup)
- 24 System pump
- 25 Boiler flow
- 26 Bent isolator - CV fitted (22mm to FF3/4")

Optional Equipment Kits For BMST-SPPP

1. Sealed primary header tank kit (BCK002)
2. Switch Back up conversion 6kW to 3kW kit (BCK003)
3. Timer kit (BCK004)
4. Sealed system ROBOKIT (BCK005)
5. Pump over run kit (BCK007)
6. DHW scale prevention kit (BCK008)

Full details of the optional kits, available at the time of order, on page 34.

SELECTION

Technical Specification BoilerMate SP Pre-Plumbed				
Product Stock Code		BMSTSP150PP	BMSTSP180PP	BMSTSP210PP
Energy efficiency class		C	C	C
Heat loss	watts	47	55	62
	kWh/24hr	1.48	1.78	2.08
Height	mm	1118	1306	1494
Diameter	mm	550	550	550
Min cupboard height ¹	mm	1668	1856	2044
Min cupboard width	mm	670	670	670
Min cupboard depth	mm	670	670	670
Weight (empty)	kg	42	46	55
Weight (full)	kg	193	227	266
Thermal store volume	litres	151	181	211
DHW dedicated volume	litres	151	181	211
DHW space heating volume	litres			
Average reheat power ²	kW	21	19	19
Average reheat time ³	mins	18	26	29
Maximum DHW pressure	bar	5	5	5
DHW performance				
Test flow rate	litres/min	12.6	12.6	12.6
Test volume above 40°C	litres	138	154	196
Average DHW temperature	°C	54	53	55
Average temperature rise	°C	41	41	43
Thermal store test temperature	°C	75	75	75

Notes:-

1. The height stated is to the top of the unit plus 550mm, which should allow for a 25mm thick shelf/board and room for servicing. This will need to be increased by 125mm if the automatic fill method is chosen.
2. SP model heated from a heat source at 82.5°C at 16 l/m.
3. Full thermal store volume reheated from 35°C to 75°C.
4. Please refer to page 5 for the minimum cupboard space requirement. This can be reduced by approximately 70mm if the insulation is removed from the plate heat exchangers.

TRANSPORT

Preparation / Placing The Appliance In Position

The appliance should be handled carefully to avoid damage and the recommended method is shown above.

Note: Although the above guidance is provided any manual handling/lifting operations will need to comply with the requirements of the Manual Handling Operations Regulations issued by the H.S.E.

The appliance can be moved using a sack truck on the rear face although care should be taken and the route should be even.

In apartment buildings containing a number of storeys we would recommend that the appliances are moved vertically in a mechanical lift.

If it is proposed to use a crane expert advice should be obtained regarding the need for slings, lifting beams etc.

Before installation the site requirements should be checked and confirmed as acceptable.

Manual Handling Of The Appliance

Manual handling means any transporting or supporting of a load (including lifting, putting down, pushing, pulling, carrying or moving) by hand or bodily force.

Scope

This assessment will cover the largest unit within each product range.

For specific weights and dimensions please refer to technical data section.

Main Hazards

Vision may not be clear due to the size of the products. Adopting an incorrect method of lifting may cause injury, attempting to lift these products will require help from others. (Team lifts)

Manual Lifting Procedure

The lift, key factors in safe lifting are:

- a. **Balance**
 - b. **Position of back**
 - c. **Positioning of the arms and body**
 - d. **The hold**
 - e. **Taking the lead for team lifts**
- a. **Balance** - Since balance depends essentially upon the position of the feet, they should be apart about hip breadth with one foot advanced giving full balance sideways and forward without tension. In taking up this position, lifting is done by bending at the knees instead of the hips and the muscles that are brought into use are those of the thigh and not the back.
 - b. **Position of back** - Straight - not necessary vertical. The spine must be kept rigid, this coupled with a bent knee position, allows the centre line of gravity of the body to be over the weight so reducing strain.
 - c. **Positioning of arms and body** - The further arms are away from the side, the greater the strain on the shoulders, chest and back. Keep elbows close to the body arms should be straight.

- d. **The hold** - Before lifting ensure you have a good hold.
- e. **Taking the lead for team lifts**- As more than one person is required for these products ensure that one person is taking the lead. **This may be you** so ensure that each person that is helping is made aware of the weight and of the items listed within this assessment. Make sure you and any others helping know the route you intend to take that it is clear of any obstructions. Never jerk the load as this will add a little extra force and can cause severe strain to the arms, back and shoulders. If there are steps involved decide on where you will stop and take a rest period. Move smoothly and in unison taking care to look and listen to others helping with the lift. Where possible use a sack truck to move the product over long flat distances, only lift the products when necessary. If in doubt stop and get more help.

Individual Capability

Individual capability plays an important part in handling these products. Persons above average build and strength will find it easier and should be in good health. Persons below average build and strength may require more rest periods during the handling process.

Pregnant women should not carry out this operation.

Persons who are not in good health should seek medical advice prior to commencing any lifting or manual handling operation.

Residual Risk

Following the guidelines given above will reduce any risk to injury.

All persons carrying out this operation must be fully trained and copies of the specific risk assessment made available for inspection and use in their training process.

Further guidance on Manual Handling can be obtained from the Health and Safety Executive. Manual Handling Operations Regulations 1992 (amended by Health and Safety (Miscellaneous Amendments) Regulations 2002).

INSTALLATION

Pipe Sizing / Materials / Push Fit

To achieve even distribution of the available supply of hot and cold water, it is important in any mains pressure system, that the piping in a dwelling should be sized in accordance with BS EN 806:1-5: BS EN 8558:2011. This is particularly important in a large property with more than one bathroom.

However, the following rule of thumb guide lines should be adequate for most smaller property types as long as water pressures are within the recommended range.

1. A 15mm copper or equivalent external service may be enough for a small 1 bathroom dwelling (depending upon the flow rate available), but the minimum recommended size for new dwellings is 22mm (25mm MDPE).
2. The internal cold feed from the main incoming stop tap to the BoilerMate SP should be run in 22mm pipe. The cold main and hot draw-off should also be run in 22mm as far as the branch to the bath tap.
3. The final branches to the hand basins and sinks should be in 10mm and to the baths and showers in 15mm (1-meter minimum).
4. **We would recommend that best results for a balanced system are achieved by fitting appropriate flow regulators to each hot and cold outlet. This is particularly relevant where the water pressures are above the recommended water pressure range. Details of suitable flow regulators are provided in Appendix A.**

All the recommendations with regard to pipework systems in this manual are generally based on the use of BS/EN Standard copper pipework and fittings.

However, we are happy that plastic pipework systems can be used in place of copper internally as long as the chosen system is recommended for use on domestic hot and cold water systems by the manufacturer and is installed fully in accordance with their recommendations. This is particularly important in relation to use of push fit connections when using the optional flexible hose kits - see installation section of this manual.

It is also essential that if an alternative pipework material/system is chosen the manufacturer confirms that the design criteria of the new system is at least equivalent to the use of BS/EN Standard copper pipework and fittings.

Secondary Circulation

If the length of the hot water draw off pipework is excessive and the delivery time will be more than 60 seconds before hot water is available at the tap, you may wish to consider using trace heating to the hot water pipework such as the Raychem HWAT system. Also, a conventional pumped secondary circulation system (shown below) can be used with any model of the BoilerMate SP.

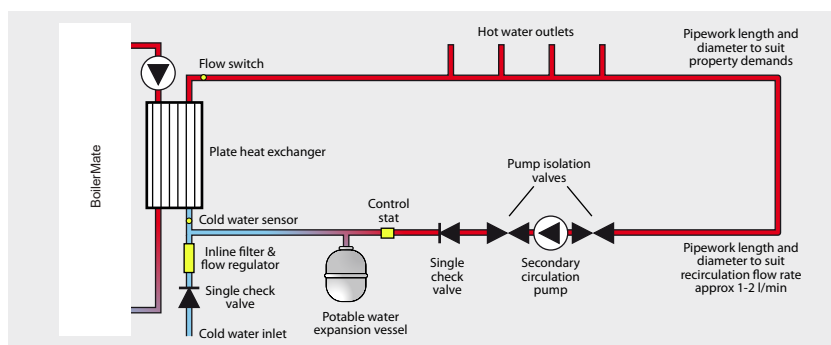

A pipe thermostat is incorporated in the circuitry which cuts the supply to the pump when the water in the return pipe reaches the set temperature. Ensure the hot water temperature is set correctly to avoid excessively hot water at the outlets and long pump run times.

Secondary circulation pipework must be insulated to prevent energy loss in both heated and unheated areas.

Bath Hot Water Temperature

Bath hot water supplies should be limited to a maximum of 48°C using an inline blending valve.

Pipe Separation

It is important that the cold-water pipework is adequately separated/protected from any heating/hot water pipework to ensure that the water remains cold and of drinking water quality.

Tap outlets

Aerated taps are recommended to prevent splashing.

Showers

Any type of shower mixing valve can be used as long as both the hot and cold supplies are mains fed. However, all mains pressure systems are subject to dynamic changes particularly when other hot and cold taps/showers are opened and closed, which will cause changes in the water temperature at mixed water outlets such as showers. For this reason and because these are now no more expensive than a manual shower we strongly recommend the use of thermostatic showers with this appliance. The shower head provided must also be suitable for mains pressure supplies.

However, if it is proposed to use a 'whole body' or similar shower with a number of high flow/pressure outlets please discuss with the Gledhill technical department.

Shower Pipework

The hot water supply to a shower-mixing valve should be fed wherever practical directly from the BoilerMate or be the first draw off point on the hot circuit. The cold supply to a shower-mixing valve should wherever practical be fed directly from the rising mains via an independent branch. The shower must incorporate or be fitted with the necessary check valves to provide back-siphonage protection in accordance with the Water Regulations.

Bidet Supply

The supply of hot and cold mains water directly to a bidet is permitted provided that it is of the over-rim flushing type and that a type 'A' air gap is incorporated.

INSTALLATION

Domestic Hot Water Controls Wiring

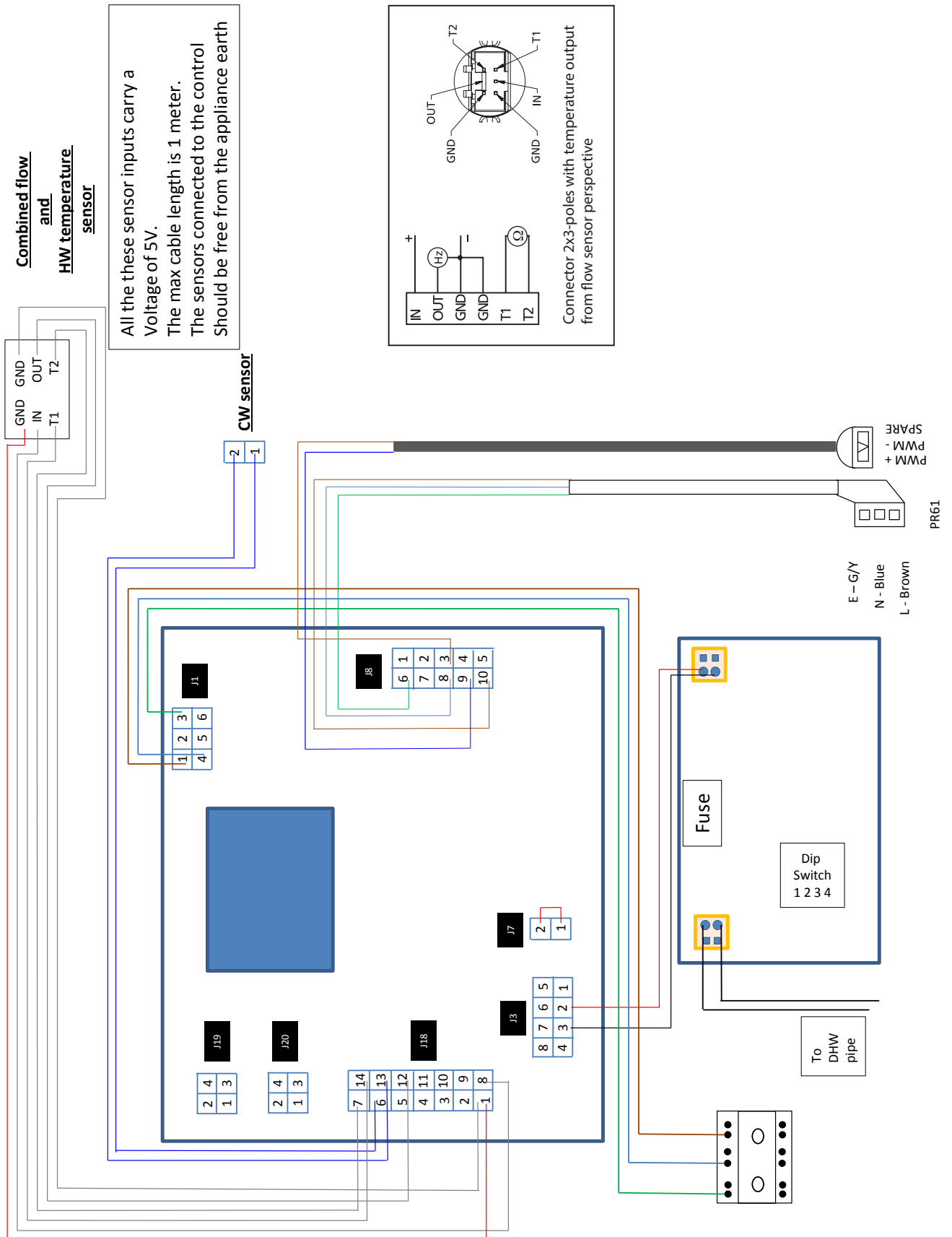

INSTALLATION

Domestic Hot Water Performance Test Flow rates

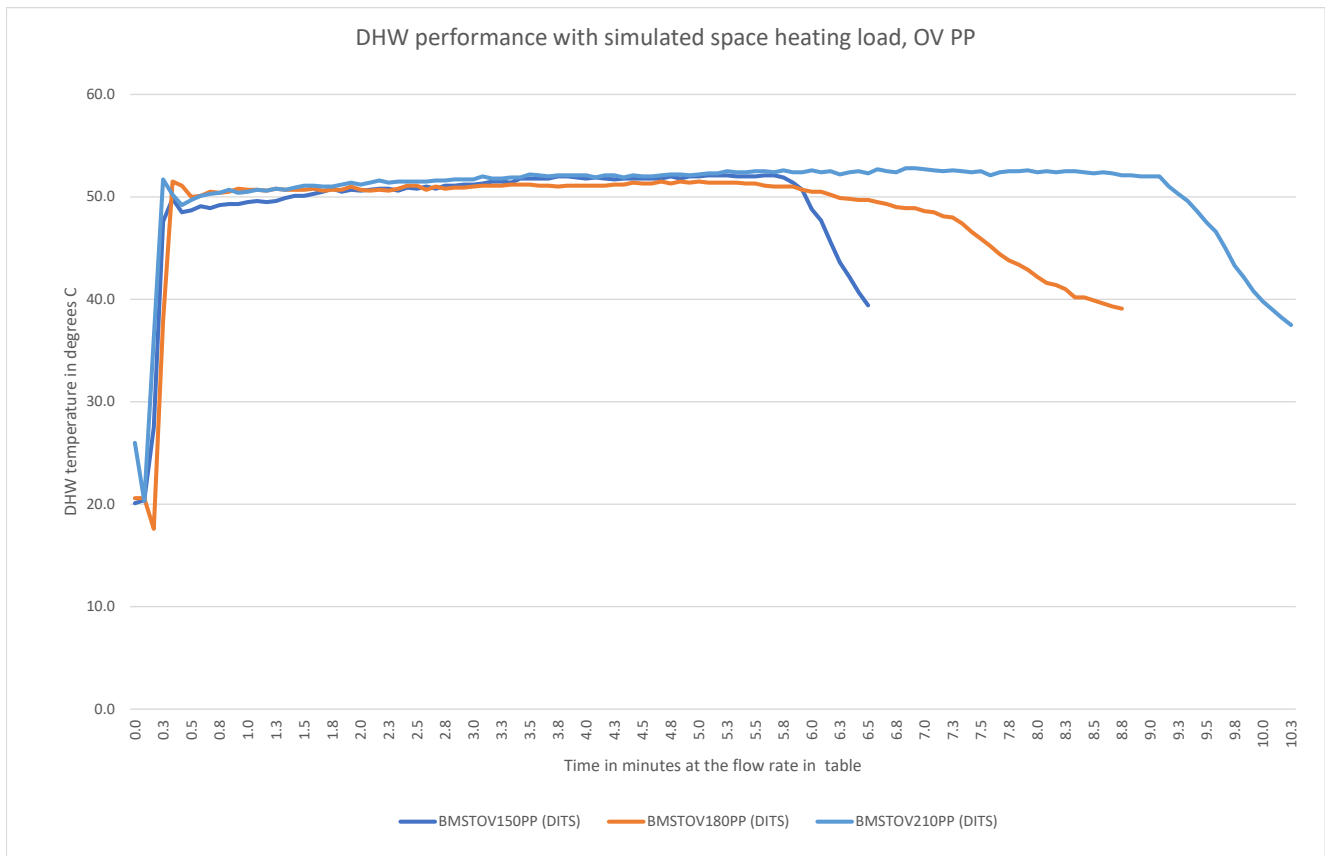
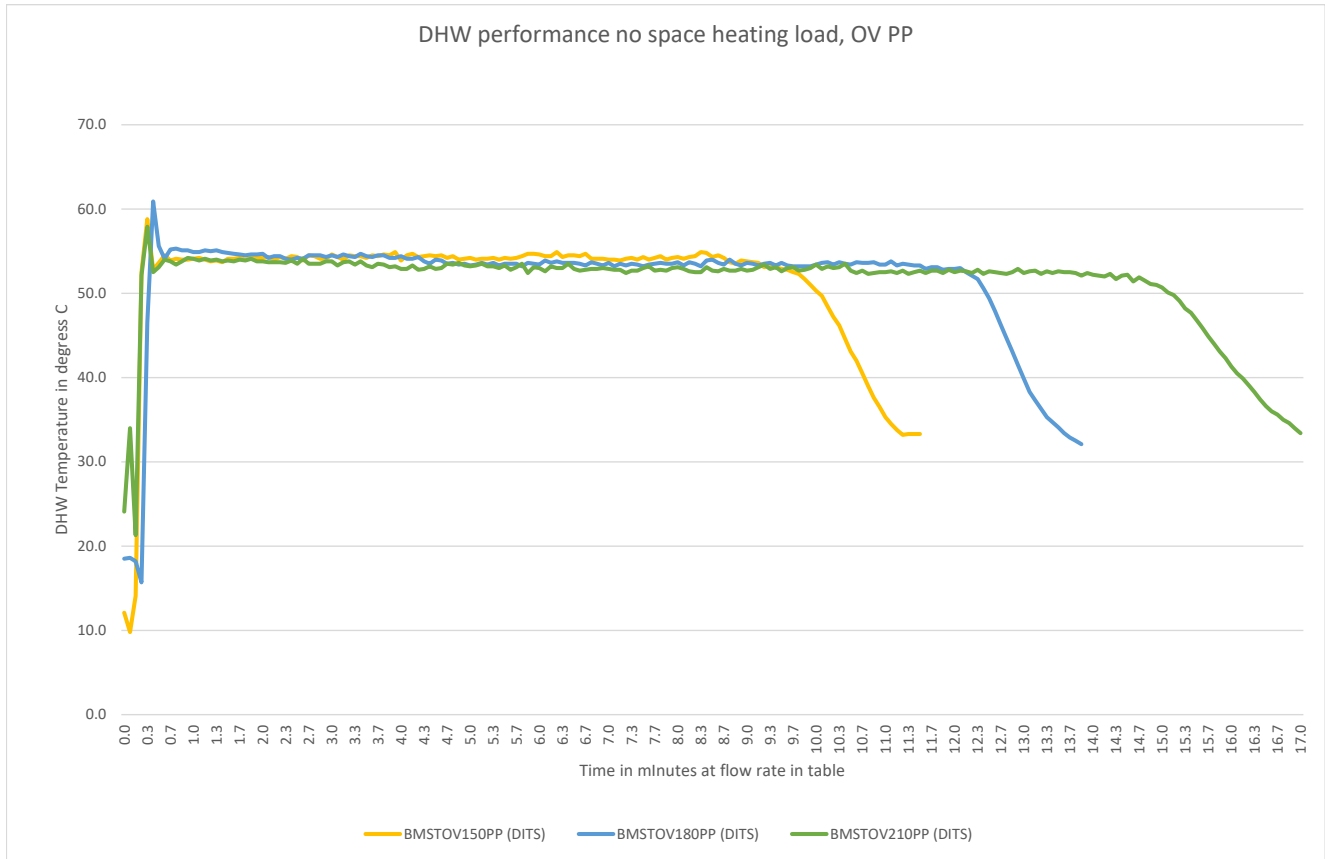

INSTALLATION

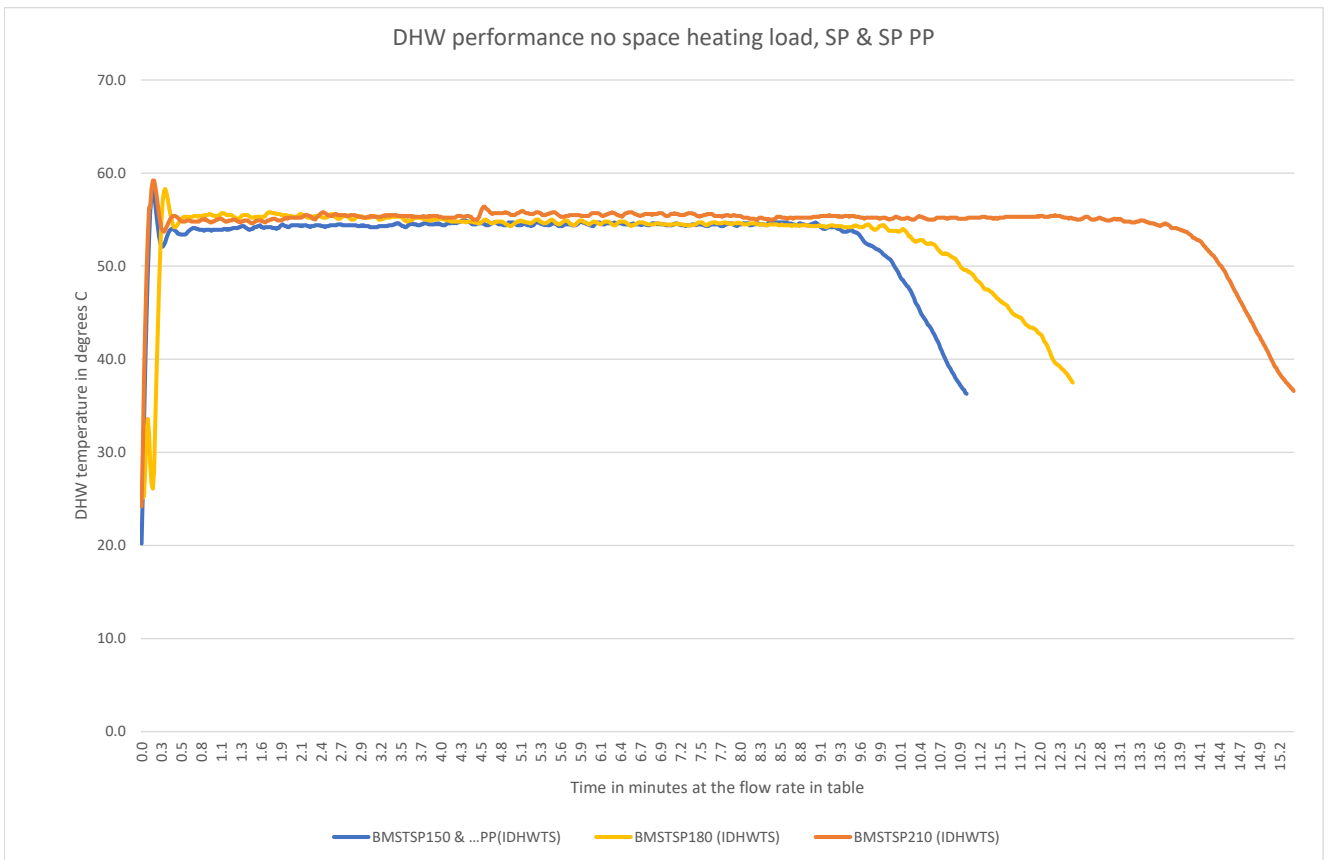

Hot water draw off volume VHW-N

Product reference	DHW flow rate		Hot water delivery temperature		Thermal store temperature		HW delivered above 40 degrees C	
	[l/sec]		[°C]		[°C]		[Litres]	
	Target	Actual	Nominal	Actual	Nominal	Actual	Min	Actual
BMSTOV150PP (DITS)	0.21	0.21	55	54	75	75	94	138
BMSTOV180PP (DITS)	0.21	0.21	55	53	75	75	113	154
BMSTOV210PP (DITS)	0.21	0.21	55	55	75	75	131	196

Product reference	DHW flow rate		Hot water delivery temperature		Thermal store temperature		HW delivered above 40 degrees C	
	[l/sec]		[°C]		[°C]		[Litres]	
	Target	Actual	Nominal	Actual	Nominal	Actual	Min	Actual
BMSTSP150 (IDHWTS)	0.21	0.21	55	54	75	75	0	138
BMSTSP180 (IDHWTS)	0.21	0.21	55	53	75	75	112	154
BMSTSP210 (IDHWTS)	0.21	0.21	55	55	75	75	130	196

Pressure Flow Characteristics Of The DHW Heat Exchanger

Flow (l/m)	Pressure Drop (bar)
0	0
6.3	0.121516
7.5	0.168105
9.45	0.258502
11.25	0.357679
12.6	0.441755
13.86	0.527598
15	0.611323
15.75	0.669513
16.5	0.730151
18.75	0.926607

Hot water draw off volume VHW-L

Product reference	DHW flow rate		Hot water delivery temperature		Thermal store temperature		HW delivered	
	[l/sec]		[°C]		[°C]		[Litres]	
	Target	Actual	Nominal	Actual	Nominal	Actual	Min	Actual
BMSTOV150PP (DITS) load	0.21	0.20	55	50	61	61	72	78
BMSTOV180PP (DITS) load	0.21	0.20	55	49	62	63	86	103
BMSTOV210PP (DITS) load	0.21	0.21	55	51	63	63	101	137

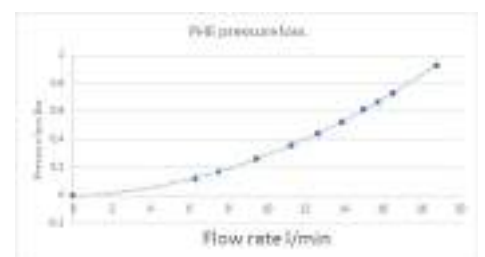

INSTALLATION

Sealed And Open Vented Systems

The Boilermate OV-PP product range is an integrated thermal store which supplies space heating from the thermal store. The Boilermate SP and SP-PP product ranges are hot water only thermal stores where the space heating is supplied directly from the boiler.

In all three ranges the thermal store itself is open vented and requires a correctly sized feed and expansion tank. The OV-PP product range requires enough expansion for the space heating and the thermal store volumes. The SP and SP-PP product ranges expansion only for the thermal store volumes.

In all cases

- Combined cold feed and open vent pipe arrangements must not be used.
- No valve should be fitted in the safety open vent.
- The safety vent must be a minimum of 22mm copper pipe or equivalent.

The Boilermate OV-PP's space heating system and boiler must be open vented. The Boilermate SP's and SP-PP's space heating system and boiler can be either open vented or sealed; the expansion system for the thermal store and the boiler/space heating system are separate.

Maximum Installed Radiator Capacity

The maximum radiator capacity is limited by the power of maximum head/pressure being delivered by the pump, and the maximum power of the boiler. To maximize the heat output the pipe diameters must be sized to enable the boiler output to reach the thermal store and the radiators. The boiler should be sized appropriately for the system that it is being fitted into.

It is the systems designer's responsibility to determine what these are.

INSTALLATION

Pumps Supplied With BoilerMate Products

GBP part code	XB530	XB531	XB532
WILO Pump type	Ku15-130/7 iPWM2	25-130/6SC	Ku15/6-43/SC
Pump housing type	Ku = inline Composite OEM	- = Inline cast iron pump housing	Ku = inline Composite OEM
Threaded connection DN	15	25	15
Pump housing length	130	130	130
Maximum delivered head	7	6	6
Maximum power consumption [Watts]	50	43	43
Control box orientation	6 o'clock	6 o'clock	12 o'clock
Function	Store pump for DHW PHE	Space heating and/or Boiler PHE	Store pump for Boiler PHE
Control	iPWM 2	SC - Push button	
Speed	PWM2 speed controlled by PCB	Variable Pressure x 3 defined curves	
		Constant Pressure x 3 defined curves	
		Constant Speed x 3 defined curves	
Product used on			
OV-PP	x 1	x 2	0
SP-PP	x 1	x 1	x 1
SP x 1	x 1	0	x 1

INSTALLATION

Pump curves:-

The XB530 pump curve is not included below because it is not relevant to the installation of the product. The XB530 (25/6) and XB531 (15/6) pump curves are identical and are shown below. Both XB530 and XB531 are supplied set at constant speed III.

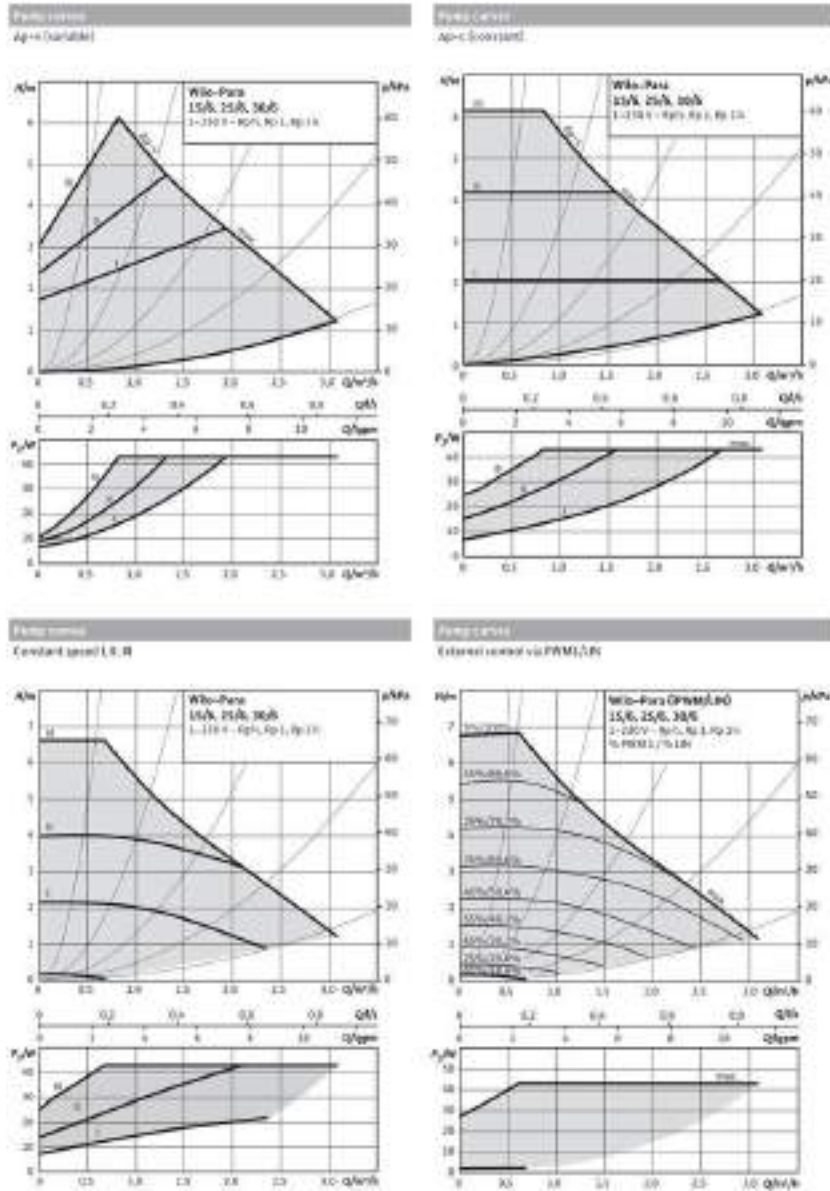

Differential Pressure Variable $\Delta p-v$ (I, II, III)

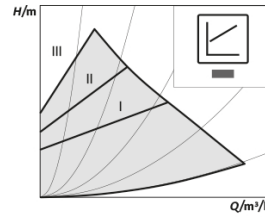

Recommended for two-pipe heating systems with radiators to reduce the flow noises at thermostatic valves.

Constant differential pressure $\Delta p-c$ (I, II, III)

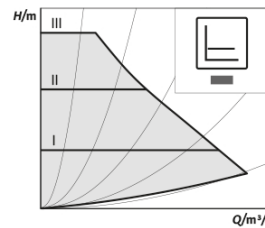

Recommended for underfloor heating or for large-sized pipes, applications without a variable pipe network curve (e.g. storage charge pumps) or single pipe heating systems with radiators.

Constant speed (I, II, III)

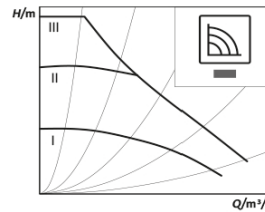

Recommended for systems with fixed system resistance requiring a constant volume flow and for replacement of AC pumps.

INSTALLATION

Push To Change The Pump Setting

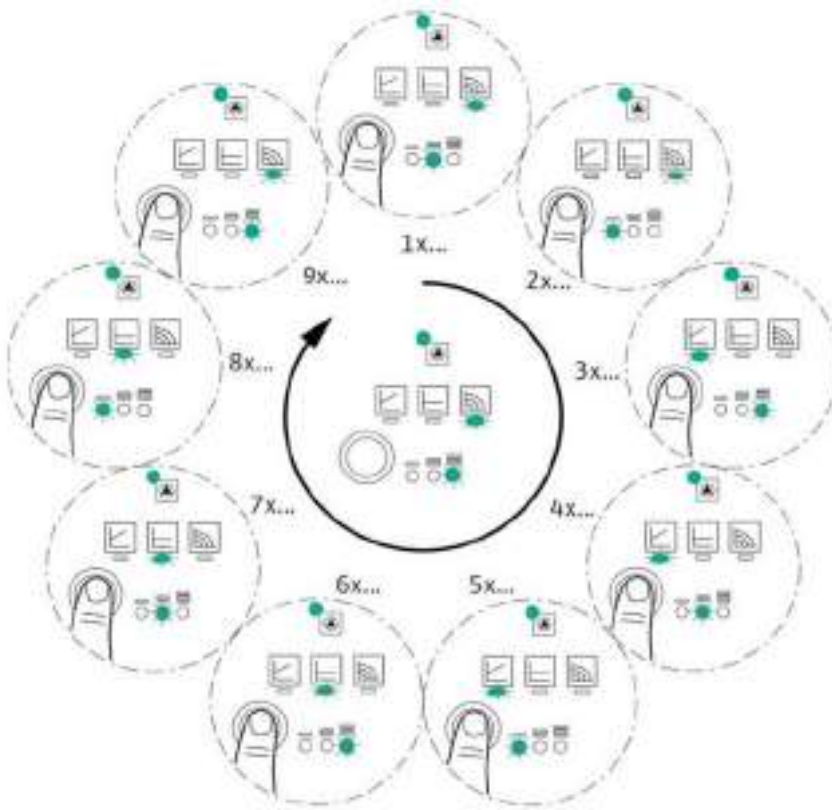

Wilo-Para Self Control / Smart Functions

Air-Venting Mode

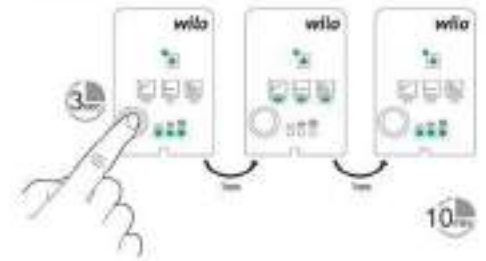

Manual Restart

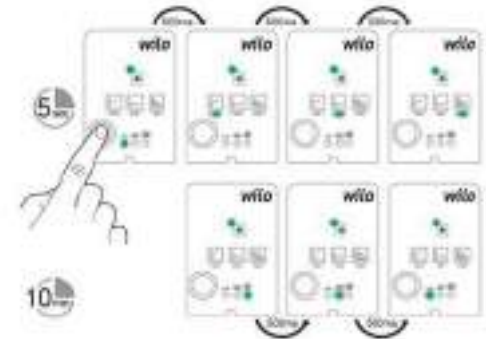

Lock and Unlock

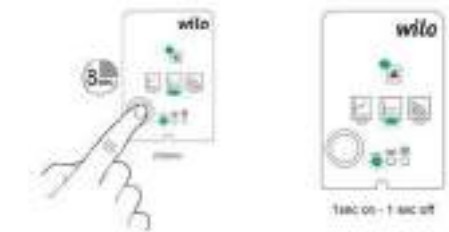

INSTALLATION

Automatic Bypass Valve

Some low water content boilers require greater flow rates than the heating load of the property requires. Please check your boiler manufacturer's instructions for requirements.

The system bypass will enable this minimum flow rate to be achieved. The 22mm straight bypass fitted to the SP-PP version has a maximum rating of 30kW. It is adjustable between 0.05 Bar and 0.5 Bar. Has a maximum working pressure of 16 Bar and intermittent working temperature of 120°C.

The valve manufacturer recommends that most domestic situations will be set between 0.2-0.3 Bar. If the flow is too high increase the pressure setting and conversely if too low decrease the pressure setting.

The bypass valve must be set by the installer to suit the system i.e. to provide minimum flow required for the boiler when all TRVs are closed, and/or when all the zone valves are closed. Benefits include reduced system noise, reduced pump impeller wear and enhanced boiler heat exchanger life.

Using the Pump curves in the previous section and the minimum flow from the boiler manufacturer's instructions determine the available pump head at the selected pump speed. Project these values on the chart below to get the valve set point.

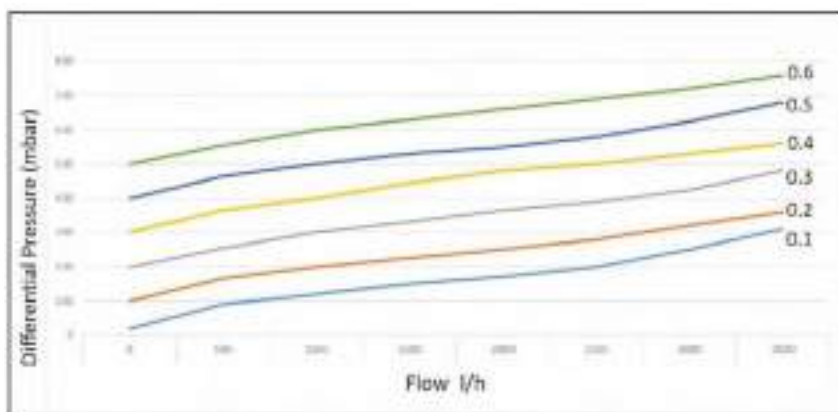

e.g For minimum flow 500 l/h and differential Pressure 200 mbar, set the valve at 0.25

INSTALLATION

BoilerMate OV PP Plumbing Schematic

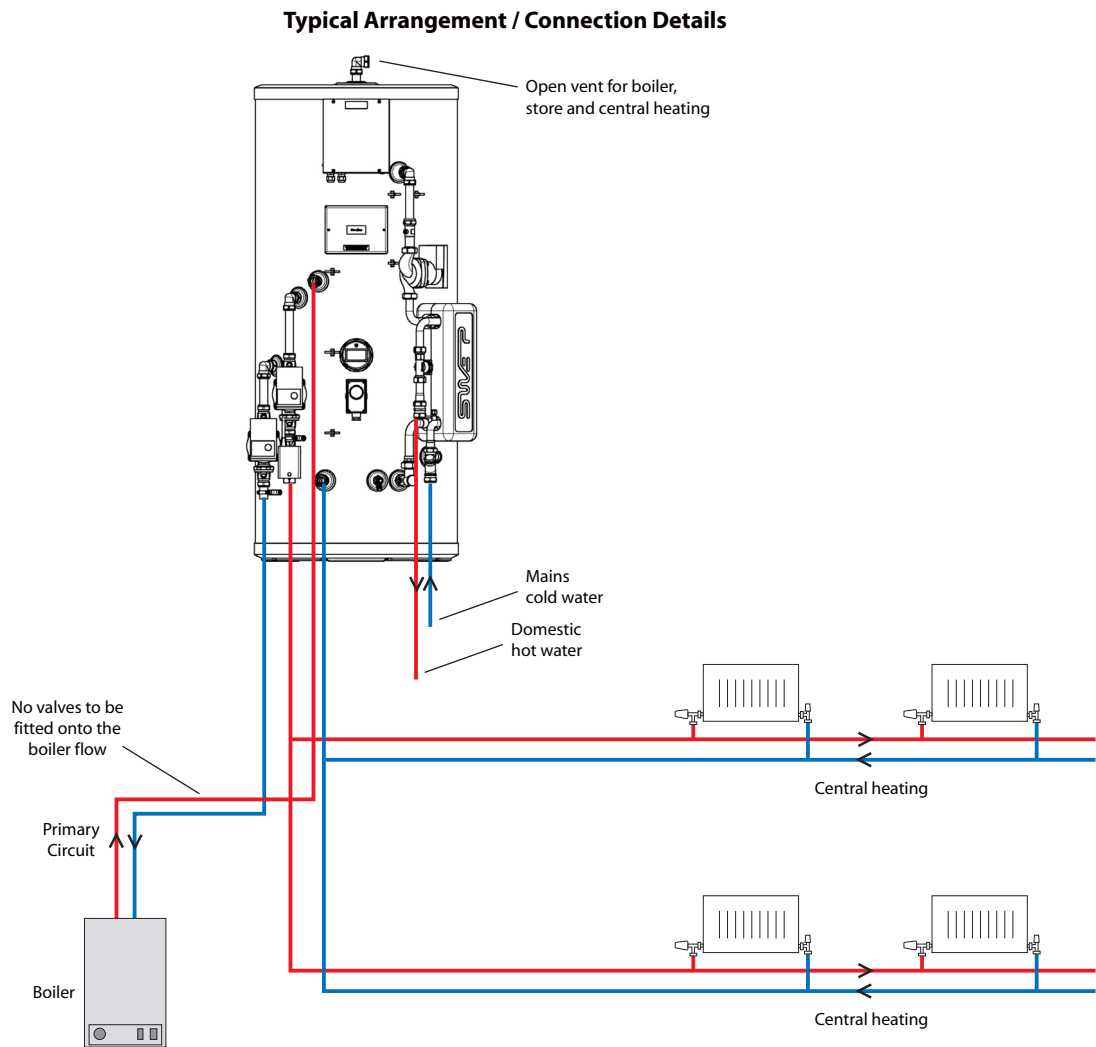

Note:

Please refer to boiler manufacturers instructions if a constant rise from the boiler to the BoilerMate is not achievable.

INSTALLATION

BoilerMate SP Plumbing Schematic (Open vented heating system)

Typical Arrangement / Connection Details

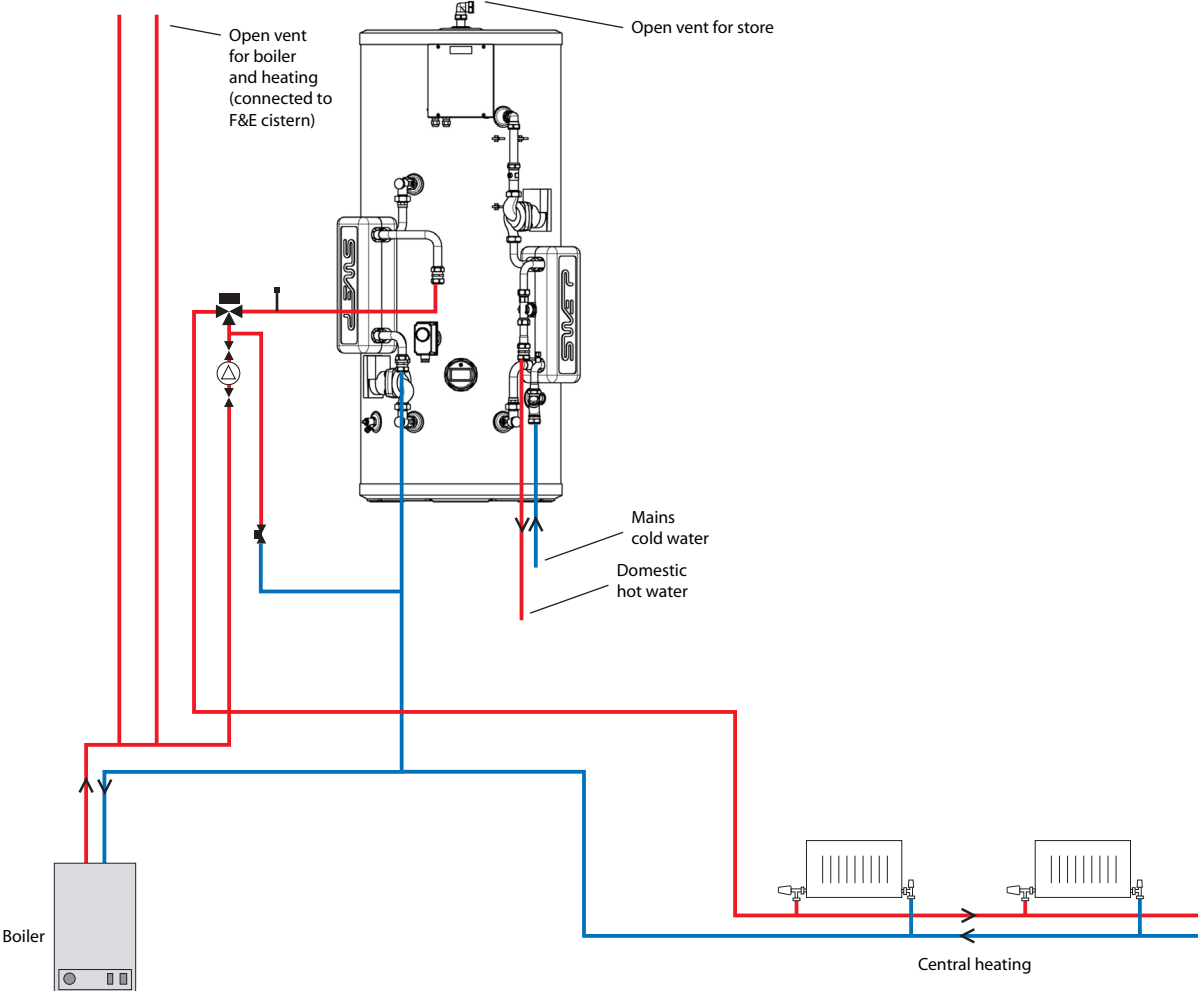

INSTALLATION

BoilerMate SP PP Plumbing Schematic

Typical Arrangement / Connection Details

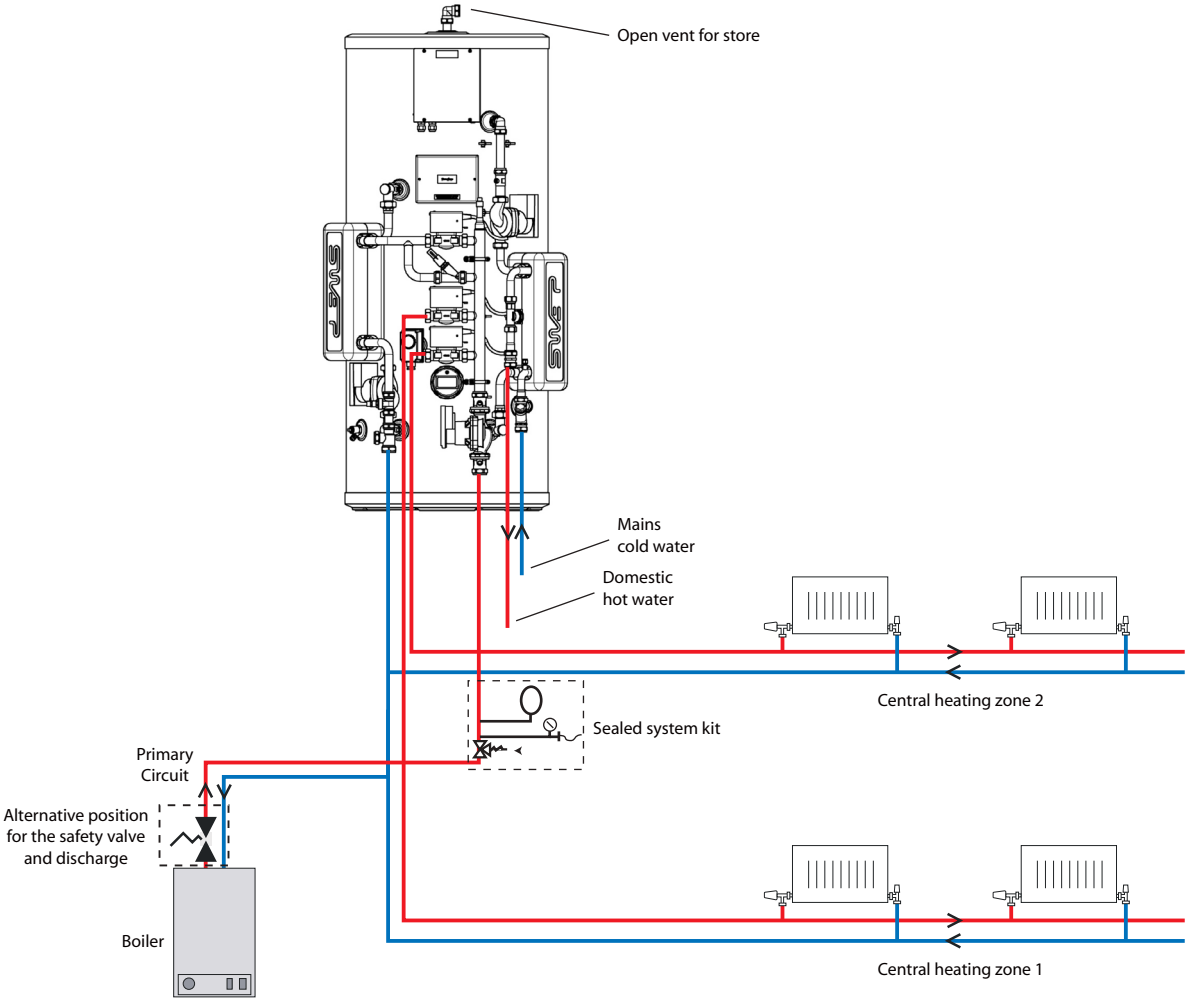

INSTALLATION

District Heating Systems

The diagram opposite shows the BoilerMate SP installed to a system where the pumped supply is adequate to overcome the pressure loss of the BoilerMate SP heat exchanger coil, the pressure loss over the central heating system components and all other components fitted to it. In addition, all the components fitted are able to withstand the pressure in the district system.

In the diagram opposite, the cold water supply to the feed and expansion cistern is not shown, and neither is the overflow pipe which may be required if the ball valve is fitted to the F & E cistern. See page 9 for further details. Potentially a temporary filling loop complying with the water regulations can be installed.

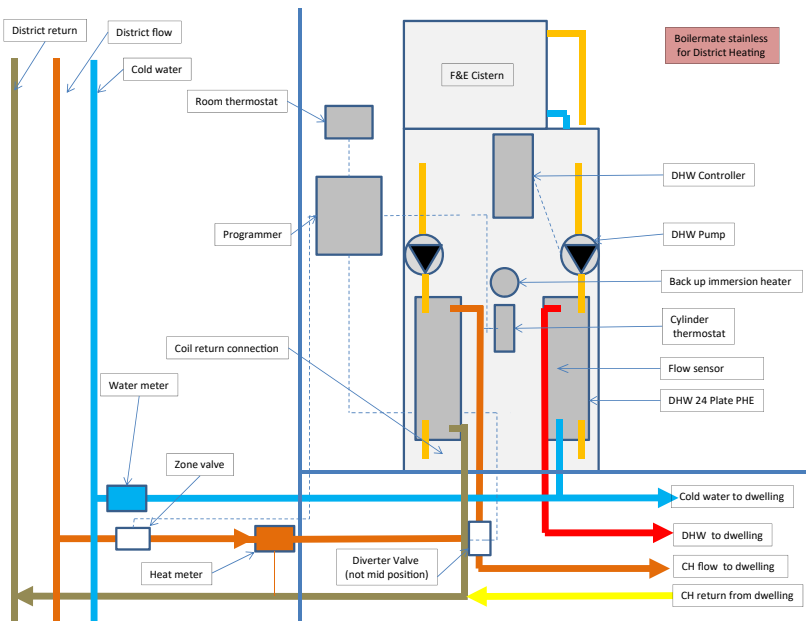

In this diagram an additional pump is shown fitted because the pressure loss in the central heating system is too large for the district pump.

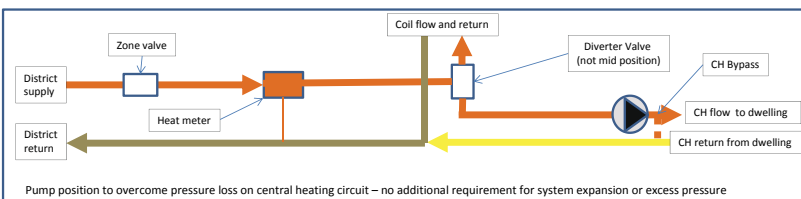

The pump is now fitted in the district supply because the pressure loss over the BoilerMate SP coil is too large.

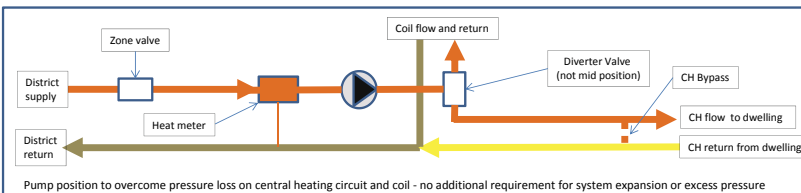

Here, the plate heat exchanger has been fitted because the expansion requirements of the central heating system are to be handled in the dwelling rather than the whole system, or the components in the central heating system are not capable of withstanding the pressure of the district heating system.

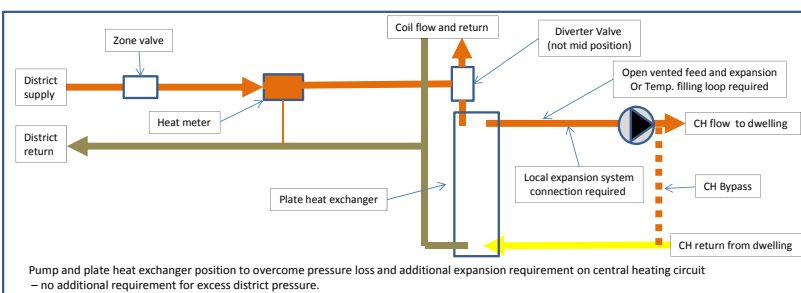

In this instance, the plate heat exchanger provides a full pressure break between the district heating system and the dwelling system. The dwelling system will need to cater for expansion and circulation requirements. This may be used where excessive district heating pressure occurs.

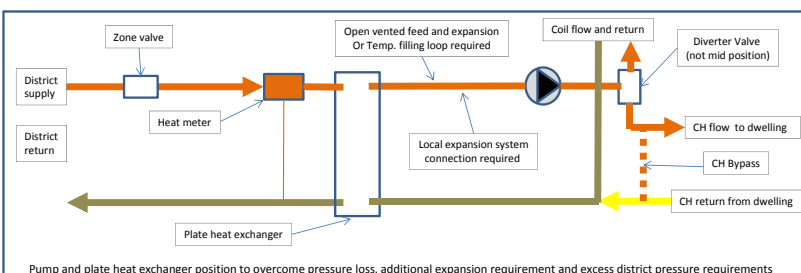

INSTALLATION

BoilerMate OV PP - 1 Zone Controls Schematic and Wiring Diagram

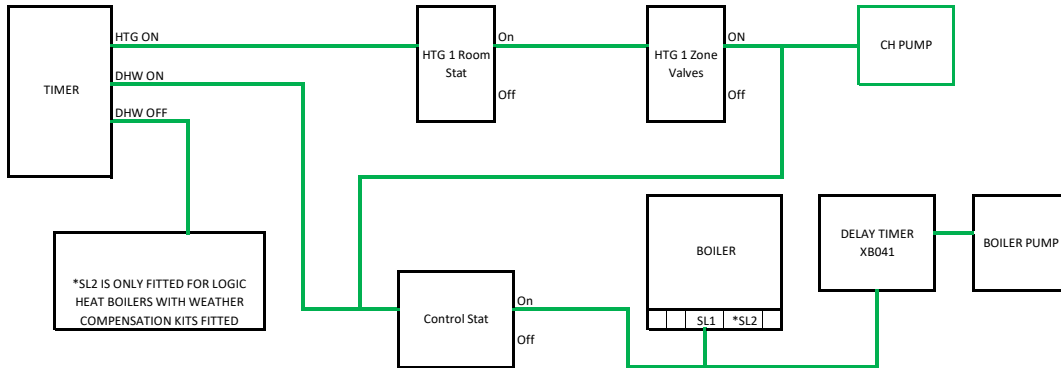

Ideal wired cylinder using Danfoss wiring centre WC4/B
BoilerMate OV pre-plumbed, 1 x 2 Port Zone Valves, Boiler Pump, CH Pump, Common Heating Time
Delay Timer XB041 fitted by installer if required

If independent times are required for each heating zone
Use programmable room thermostats and
fit live link between terminal 9 and L or set timer CH to permanent ON

Connections made by the installer

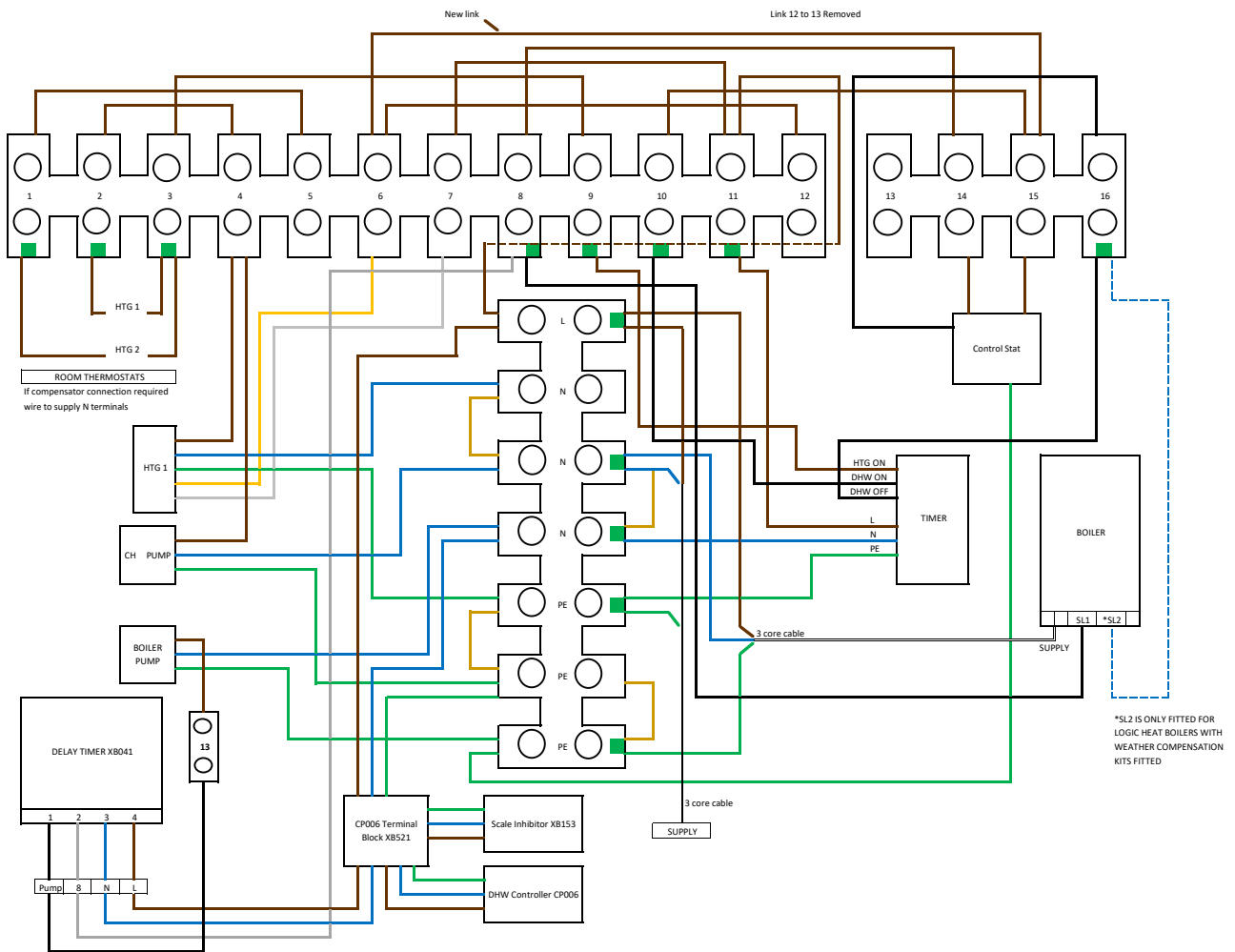

INSTALLATION

BoilerMate OV PP - 2 Zone Controls Schematic and Wiring Diagram

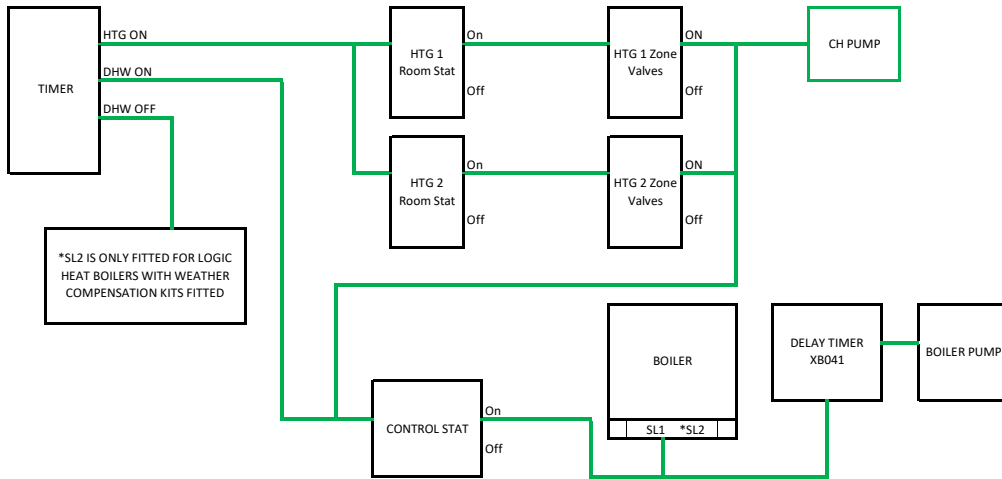

Ideal wired cylinder using Danfoss wiring centre WC4/B
BoilerMate OV pre-plumbed, 2 x 2 Port Zone Valves, Boiler Pump, CH Pump, Common Heating Times

■ Connections made by the installer

If independent times are required for each heating zone
Use programmable room thermostats and
fit live link between terminal 9 and L or set timer CH to permanent ON

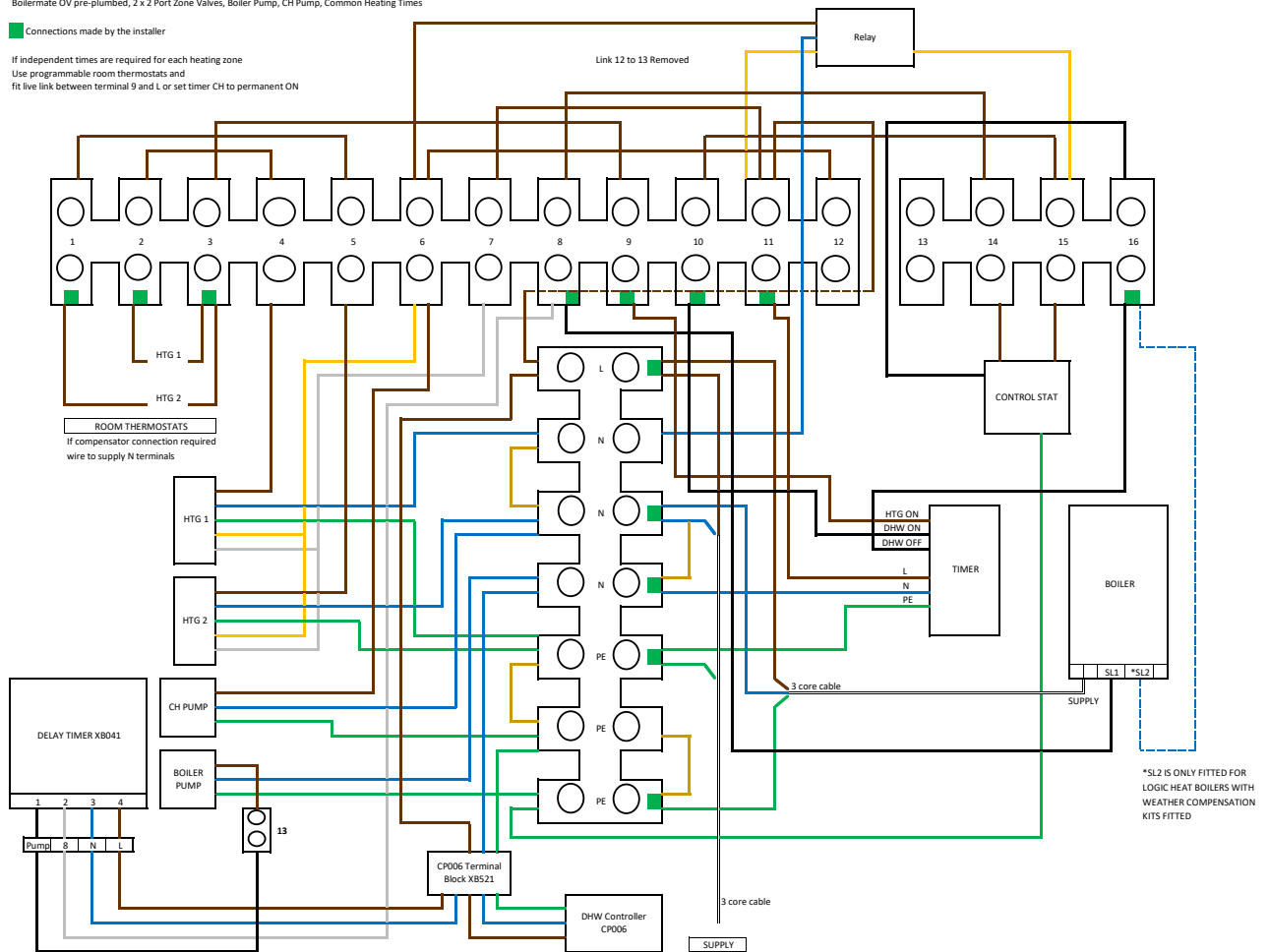

INSTALLATION

BoilerMate SP - 1 Zone Controls Schematic and Wiring Diagram

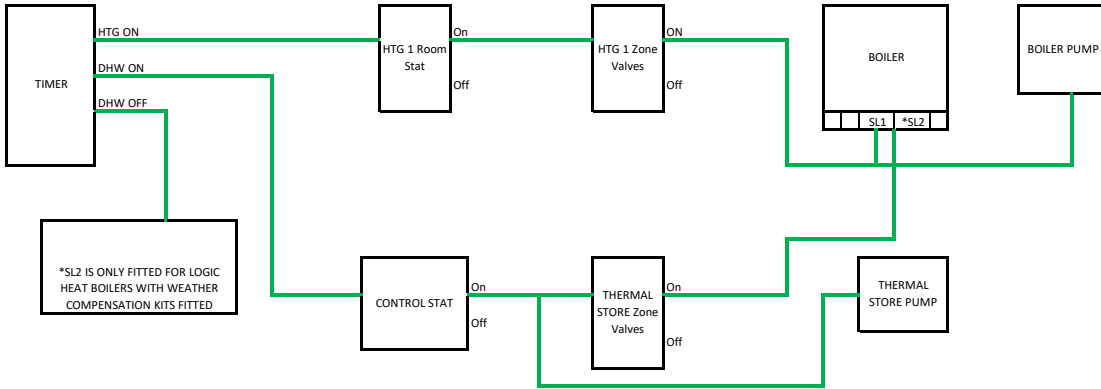

Ideal wired cylinder using Danfoss wiring centre WC4/B
BoilerMate SP pre-plumbed, 2 x 2 Port Zone Valves, Boiler Pump, Thermal Stor Pump, Common Heating Time

■ Connections made by the installer

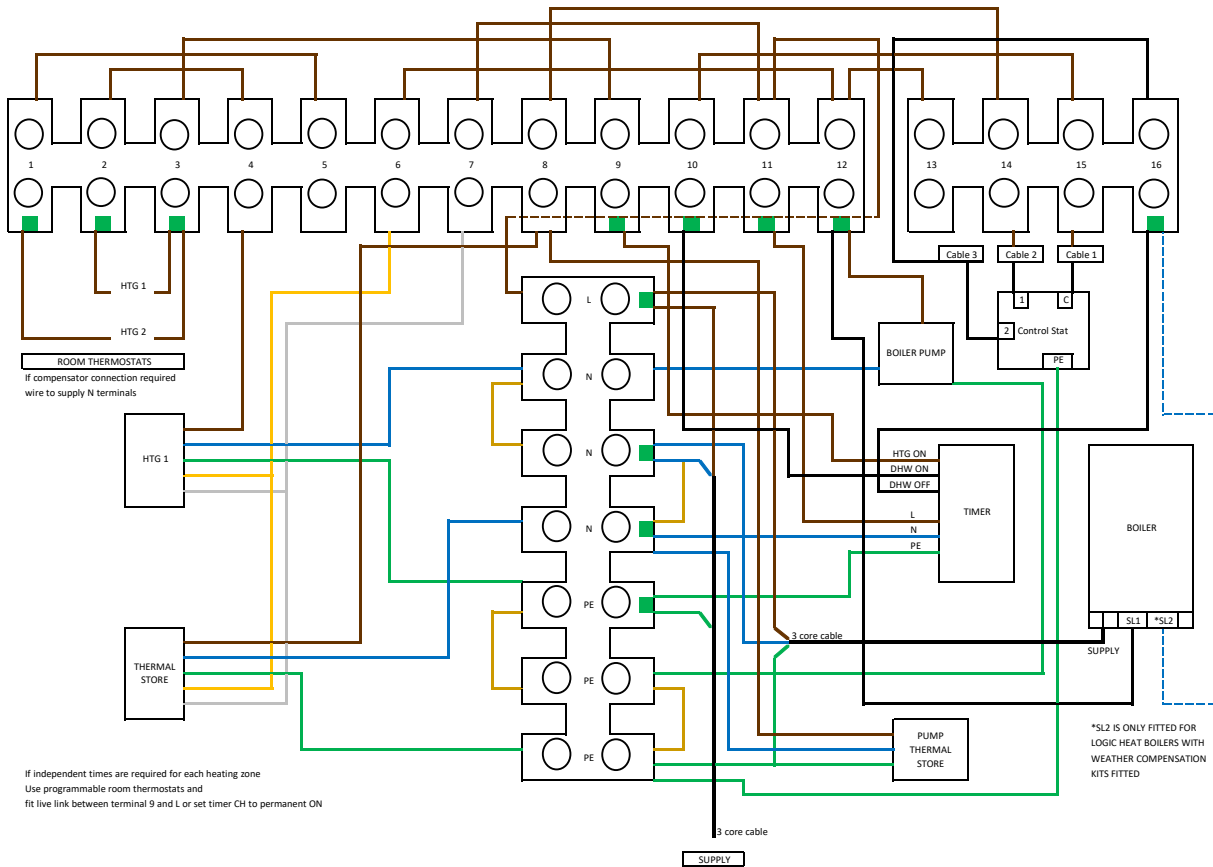

If independent times are required for each heating zone
Use programmable room thermostats and
fit live link between terminal 9 and L or set timer CH to permanent ON

INSTALLATION

BoilerMate SP PP - 2 Zone Controls Schematic and Wiring Diagram

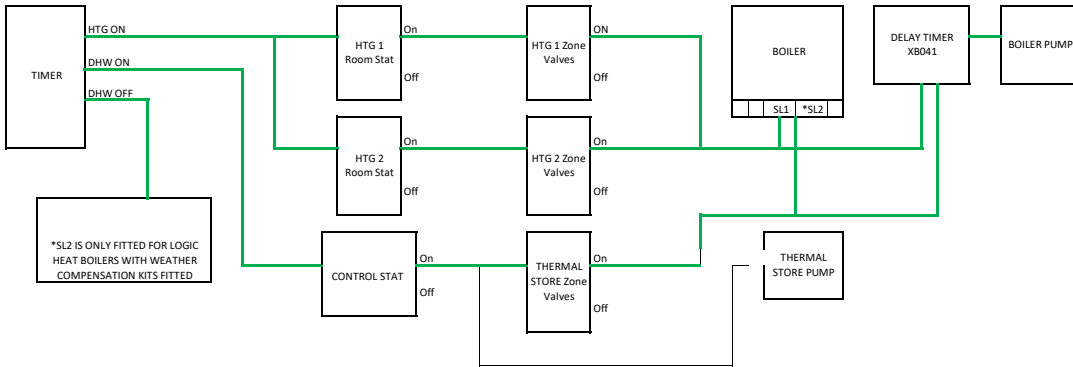

Ideal wired cylinder using Danfoss wiring centre WC4/B
BoilerMate SP pre-plumbed, 3 x 2 Port Zone Valves, Boiler Pump, Thermal Stor Pump, Common Heating Time
Delay Timer XB041 fitted by installer if required

■ Connections made by the installer

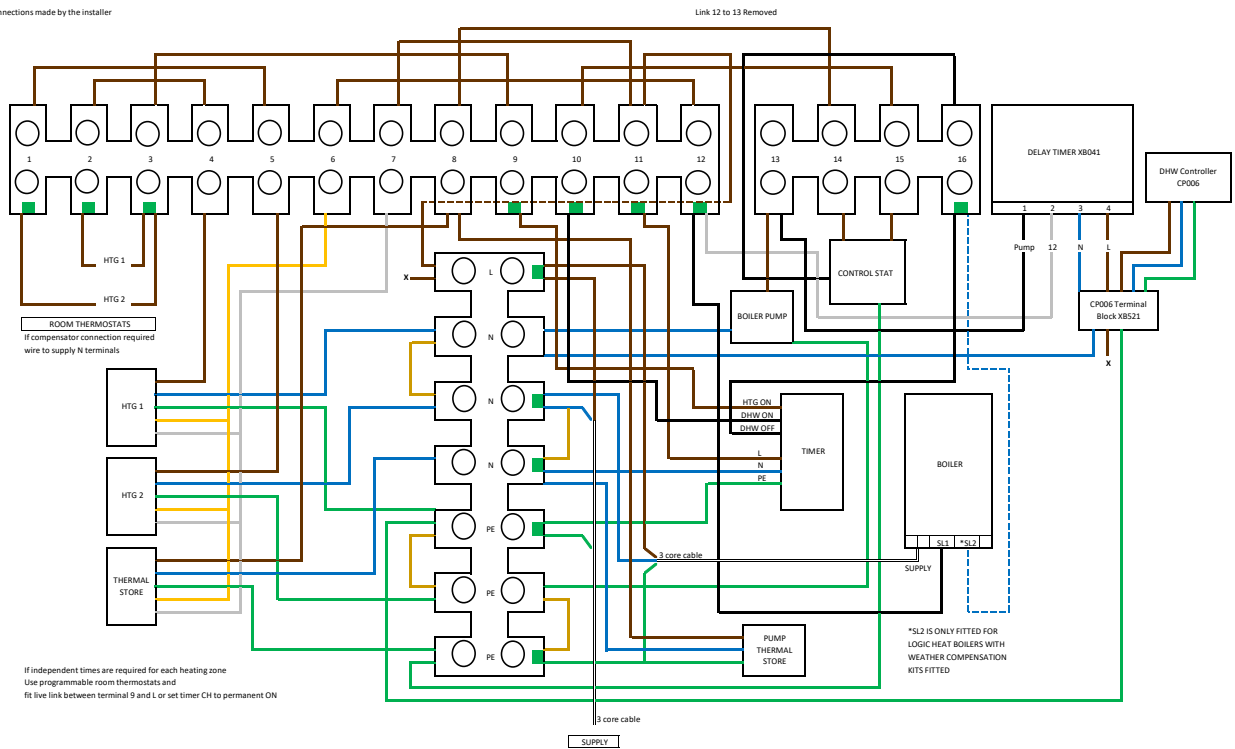

If independent times are required for each heating zone
Use programmable room thermostats and
fit live link between terminal 9 and L or set timer CH to permanent ON

INSTALLATION

Boiler Thermostat Setting

The BoilerMate OV-PP, SP and SP-PP may be installed with condensing or non-condensing oil or gas boilers. These boilers should be capable of delivering primary hot water at a minimum temperature of 80°C. To achieve the highest temperature in the thermal store and therefore maximise its performance the maximum boiler control thermostat setting must be selected.

Store Thermostat Setting

The store thermostat should be set at 75°C to achieve the maximum domestic hot water and the temperature set point of 50-55°C. We recommend this is checked during the commissioning procedure due to the tolerances on this type of thermostat.

CH control description and Thermal Store charging.

BoilerMate OV - 1 zone

The timer (programmer) is the key control for the system.

When the Central heating program is calling 240 volt AC is supplied to the Room thermostat.

If the Room thermostat is closed circuit the 240 volt AC is supplied to the heating zone valve motor. The motor runs which closes the incorporated micro switch and 240 volt AC is supplied to the central heating pump causing it to run. At the same time 240 volt AC is supplied from the zone valve micro switch to the thermal store control thermostat.

When the Hot water program is calling 240 volt AC is supplied to the Thermal store thermostat.

If the Thermal store control thermostat is closed circuit, then 240 volt AC is supplied to the boiler switch live and the boiler pump causing it to heat the thermal store. If the Delay timer is fitted and once the thermal store control thermostat is open circuit, the boiler pump will continue to run for a short period of time to remove any residual heat from the boiler.

The BoilerMate OV is placed on the market with one zone valve. If a second zone valve is required it can be purchased as a kit. [BCK006]. Please see the wiring diagram on the next page for the required modifications to the above diagram.

BoilerMate OV – 2 zone

The two-zone space heating system runs in a similar manner to the single zone. However, in this system both heating zone thermostats are supplied with 240 Volt AC simultaneously. If independent timing of the second zone is required, then another programmer or programmable room thermostat will be required. Alternatively, two programmable room thermostats can be used and the heating channel on the main programmer left permanently on.

When the Hot water program is calling 240 Volt AC is supplied to the Thermal store thermostat and if the Thermal store control thermostat is closed circuit, then 240 Volt AC is supplied to the boiler switch live and the boiler pump causing it to heat the thermal store. If the Delay timer is fitted and once the thermal store control thermostat is open circuit, the boiler pump will continue to run for a short period of time to remove any residual heat from the boiler.

BoilerMate SP PP – 2 zone

The SP two-zone space heating system runs in the same manner as the OV two zone; where both heating zone thermostats are supplied with 240 Volt AC simultaneously. If independent timing of the second zone is required, then another programmer or programmable room thermostat will be required. Alternatively, two programmable room thermostats can be used and the heating channel on the main programmer left permanently on.

The difference is that the boiler and boiler pump will always fire when there is a central heating demand.

When the Hot water program is calling 240 Volt AC is supplied to the Thermal store thermostat and

If the Thermal store control thermostat is closed circuit, then 240 Volt AC is supplied to the thermal store pump causing it to run; and to the thermal store zone valve motor. Once the motor has run the thermal store's micro switch will close and 240 Volts AC will be supplied to the boiler and boiler pump.

In addition, the delay timer will operate as described above; if fitted.

INSTALLATION

Immersion Heater

The Immersion heater supplied with the Boilermate is a 3 kW 240AC version which is supplied as a DHW back up heat source should your boiler fail at any time. The product replacement code is SH003.

Check that the mains supply conforms to this, and all external wiring conforms to the most recent revision of the IEE wiring regulations. The immersion heater is fitted into the thermal store cylinder using an O-ring. After the unit is filled with water check for leaks to determine if the O-ring has sealed and tighten carefully using the appropriate tool. To prevent damage to the O ring do not use excessive force to tighten the immersion heater.

The immersion thermostat has two terminals L and N. These should be connected as shown in the diagram. It has been our experience that crimp terminals make better connections. The immersion heater must be fully earthed (earth post) and connected via a double pole isolator switch.

The immersion heater is supplied with a thermostat which has been tested for operation in the thermal store and complies with the European directives for Electromagnetic compatibility and radio interference. It is Rated at 20 Amp 250V ~AC. The thermostat supplied with this product is set to 75°C with a safety cut out set at 90°C. The immersion heater thermostats incorporate a manual reset safety/overheat cut out thermostat. Should this operate, investigate the cause before pressing the red reset button labelled safety. If there is no apparent fault adjust the control setting down slightly to prevent nuisance tripping. If another heat source is used to heat the cylinder and this raises the water temperature excessively then the overheat thermostat will trip.

Danger of electrocution: before making any adjustments to the thermostat isolate the immersion heater from the mains electricity supply at the fuse spur unit.

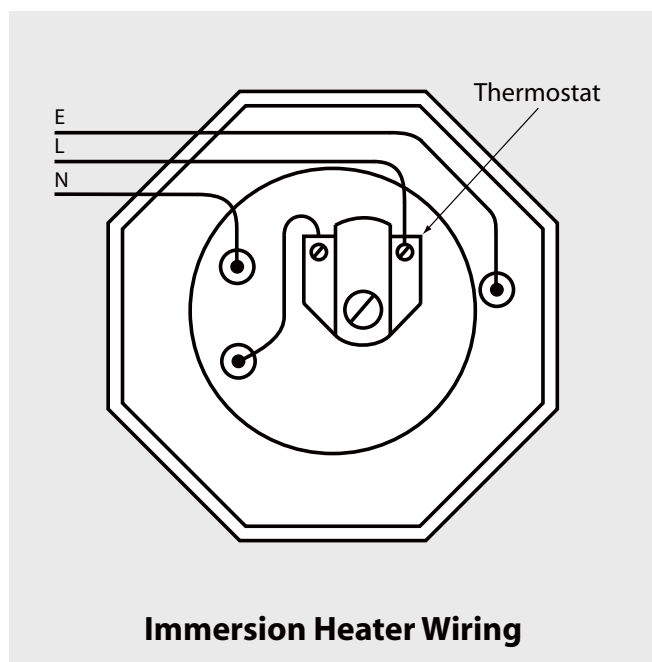

INSTALLATION

Kits

Open Vented Header Tank Kit (BCK001)

Expansion tank white c/w lid
Float Plastic Red
1/2 HP PT 2 Ball Valves
Label Water Level

Sealed Primary Header Tank Kit (BCK002)

Expansion tank white c/w lid
Label Sight Glass
22mm Tank Connector (Comp)
Sight Glass Level Indicator
22 mm 90° Compression Elbow
Tube 22 X 0.9mm X 3m
PCS F&E Pipe 22mm
Rubber Grommet
Washer Fibre

Switch Back Up Conversion 6kW to 3kW kit (BCK003)

4Way Garage Board
20A Double Pole Isolator
Single Gang Surface Mounted Box

Timer kit (BCK004)

Horstmann H27 XL

Sealed System ROBOKIT (BCK005)

18Ltr expansion vessel kit incorporating
- 18 litre expansion vessel (heating)
- Expansion Screws
- Filling loop - Double Check Valve
- Filling loop – Hose
- Filling loop - Mini Ball Valves
- ERV
- Gauge

Second Heating Zone kit (BCK006)

Zone valve 22 mm 2 port
22mm equal tee
22mm copper pipe 110mm
22mm 90° elbow
22mm copper pipe 50mm (table Y)

Pump Over Run Kit (BCK007)

Pump delay timer PCB
PCB support
M20 Cable Gland with Locknut

Dhw Scale Prevention Kit (BCK008)

Scale prevention PCB
PCB support
Scale board power harness
Scale pipe wire

- The correct settings for tube diameter 22mm is switch no. 3 on.
- Switch no. 4 can be either on or off.
- If the switch no. 4 is turned on the output electromagnetic field is generated harmoniously otherwise the field is generated inharmoniously.

COMMISSIONING

Commissioning and installation checks

All factory fitted components are tightened during manufacture, however all should be checked before installation.

Open the incoming stop valve and fill the domestic mains cold and hot water systems, the BoilerMate appliance and central heating system. Check the whole of the domestic hot and cold distribution systems for leaks, and repair if necessary.

Central heating systems should be thoroughly cleaned and flushed out before installing a new boiler. During the final filling of the system, a chemical water treatment inhibitor should be added to the primary circuit to control corrosion and the formation of scale and sludge. Note the volume of the thermal store must be included in the calculations of the amount of inhibitor required. The OV will be the combined volumes and the SP will be separate volumes. Please ensure that any chemical inhibitor used is compatible with all types of stainless steel.

Check the water level in the top up cistern and if a ball valve is fitted adjust if necessary. **If a ball valve is provided, turn down the servicing valve once the system is finally filled to the point where the warning/overflow pipe will cope with the discharge arising from a ball valve failure. If an overflow is not provided, ensure the temporary filling hose is isolated and removed from its connection to the mains water supply.**

Fully flush and if necessary, disinfect the hot and cold water system in accordance with the recommendations in the Water Regulations and BS EN 806:1-5: BS EN 8558:2011. Please note that the whole of the domestic hot and cold water systems including the appliance, must be adequately flushed after disinfection. Failure to do this may cause damage to the plate heat exchanger and other components in the DHW system. In domestic installations disinfection is not normally required.

It is essential that all systems function properly for optimum performance. To achieve this the flow rate from each tap should be checked and a suitable number of taps run simultaneously to check the impact of this on the flow rate at individual taps. **We recommend that flow regulators are provided for each tap/terminal fitting to ensure that the available flow is shared evenly - See Appendix A for further details.**

Check the Control System

Raise the BoilerMate thermal store to temperature.

During this process switch on the boost immersion heater and check it draws current using a clamp meter. Check wiring if the immersion is not drawing current.

Check that the store thermostat and immersion thermostats are switching at 75 degrees and adjust if necessary.

Run water from any hot tap to check the temperature is between 50 and 55 °C at a flow rate of 6-15l/min.

Check that the central heating system works by running it and ensure that the boiler is fired on the BoilerMate OV when the store temperature falls. The boiler should always fire when there is a central heating demand when a BoilerMate SP is fitted.

Turn off the central heating and the Boiler and the central heating pump should stop running; if a pump delay timer is fitted then the boiler pump will continue to run. If not the Boiler pump will also switch off.

If you have any doubts regarding the commissioning seek advice.

See the fault finding section of the manual for further assistance/details.

COMMISSIONING

Important Do's and Don'ts

1. **DO** check the incoming mains water pressure. The preferred range of mains pressure is 2 -3 bar.
2. **DO** check the flow rate of the incoming cold water main is adequate to meet the maximum hot and cold water simultaneous demands.
3. **DO** check that all connections are in accordance with the labelling on the thermal store.
4. **DO** check the water level is correctly set in the top up cistern when cold and if fitted that there is no overflow when the appliance is up to temperature.
5. **DO** check that the control thermostats switch the immersion heaters off at the correct set point i.e. approx 75°C.
6. **DO** insulate any exposed hot water pipework in the BoilerMate cupboard.
7. If the ballvalve in the F & E cistern is permanently connected to the mains cold water supply **DO** plumb the overflow/warning pipe in a 20mm internal diameter pipe and ensure it discharges in a conspicuous external position. Use a material which is suitable for use with heating F & E cisterns in accordance with BS 5449 (such as copper).
8. Once the appliance is filled and commissioned **DO** leave the electricity switched on to the appliance to ensure the automatic pump run facility can operate to prevent the pump sticking.
9. **DO** ensure that the functioning and control of the system is explained to the occupant.
10. **DON'T** place any clothing or other combustible materials against or on top of this appliance.

SERVICING AND MAINTENANCE

	Description	Stock Code
1	DHW PHE pump iPWM2	XB530
2	Plate heat exchanger (24 plate)	GT017
3	Pump isolating valve – outlet (90 valve)	GT135
4	Pump isolating valve - inlet (straight)	GT133
5	Immersion heater 3kW	SH003
6	Immersion thermostat	XB081
7	Main PCB controller	XB111
8	Sensors	GT198
9	Y strainer	XB314
10	Flow sensor	XB095
11	Expansion tank white c/w lid	XB343
12	Float Plastic Red 4.5"	FT429
13	1/2 HP PT 2 Ball Valves 6" arm	FT206
14	Sight Glass Level Indicator	XB443
15	Horstmann H27 XL	RP224
16	Sealed system ROBOKIT	SG032
17	Zone valve 22 mm 2 port	XG083
18	Pump delay timer PCB	XB041
19	Scale prevention PCB	XB153
20	Space heating and /or Boiler PHE pump	XB531
21	Store PHE pump	XB532
22	Store Thermostat	XC010

For any parts not listed above, please contact Gledhill Technical Support on 01253 474584, who will be able to assist (eg washers, bent pipe etc).

SERVICING AND MAINTENANCE

Annual Servicing

No annual servicing of the BoilerMate is necessary.

However, if required, the operation of the controls and a hot water performance test can be carried out to prove the appliance is working satisfactorily and within its specification.

If it is decided to carry out the above tests the water level in the top cistern should also be checked and if necessary topped up.

Changing Components

Free of charge replacements for any faulty components are available from Gledhill during the in-warranty period on return of the faulty part (normally 12 months).

After this, spares can be obtained direct from Gledhill Spares or through any of the larger plumbers merchants/specialist heating spares suppliers.

Help and advice is also available from the Technical Helpline on 01253 474584.

However, all components are readily accessible and can be changed quickly and easily by the installer using common plumbing/electrical practice.

Note: All maintenance work on the BoilerMate appliance must be carried out by a competent trades person.

SERVICING AND MAINTENANCE

Circulating Fluid In Thermal Store Pipework

- The BoilerMate and the thermal store pipework must have completed filling prior to switching the electricity supply to the PWM controller PCB. If there is no water in these pipes then there may be significant wear on the PWM pump.
- This can be confirmed by
 - Checking the thermal store pipework servicing valves are open
 - Loosening the connection points on the thermal store pipework in a systematic manner and checking for water presence.
 - Confirming that the feed and expansion tank has completed filling and the servicing valve is open.

Cold Mains Water Supply To Plate Heat Exchanger And Hot Water Taps

- Confirm that the CW mains stop valve is open
- Open all HW taps and confirm that the water runs freely and that any air is bled from the DHW system
- Determine the maximum flow rate obtained and record
- 15l/min for all BoilerMate products currently limited with a flow restrictor
- If flow rate not as expected determine the cause and rectify
 - Clean inline strainer
 - Check the flow restrictor is present and not blocked. It is located in the top of the inline strainer

Power On

- Switch on the Local fuse spur and observe the PWM pump
- Open a HW tap and observe the PWM pump
- The green LED will be constantly lit showing the pump has a power supply and is running to generate HW

NOTE: -The thermal store will only produce hot water when it is hot enough. A mid 40°C thermal store temperature will provide some hot water, higher thermal store temperatures will provide more.

Inline Scale Inhibitor (If Fitted)

- Check power supply
- PWM Controller PCB supplies a maximum of 12vDC/300mA to the Scale inhibition board. (From J3)
- Check dip switches set correctly

SERVICING AND MAINTENANCE

Test Equipment

The initial assumption in this procedure is that the plumbing and water supply is working effectively. If in doubt please confirm and refer to the end of this section for advice on specific components.

A multi meter, a weir gauge and a thermometer will be required to confirm that all the components are working effectively.

The PWM controller PCB manufacturer suggests "Fluke 87 TRUE RMS Multi meter" as a suitable product. This will be able to measure;

- the frequency output from the Board to the pump
- the Duty cycle % output from the Board to the pump

Connection numbering

For reference the connections to the PCB are numbered below for

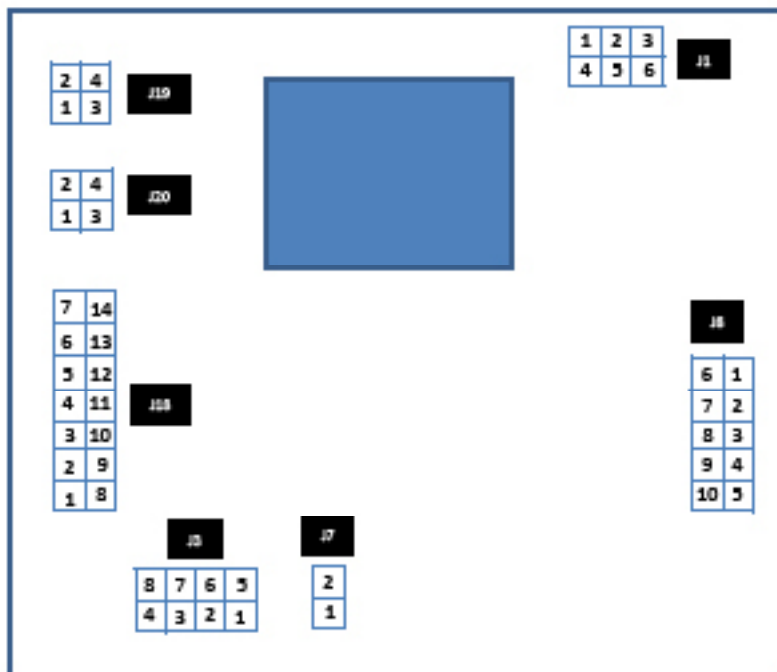

Logical sequence;

- check electrical connections fault finding section on page 23 first to ensure your own safety. This section will potentially identify any short circuited components and/or wiring faults that need to be rectified before continuing to work on the appliance.
- check that the correct information is being supplied to the board. This section will identify if any sensors are faulty or out of tolerance. These will need to be replaced before continuing
- check that the overheat link is present
- check that the outputs to the board are being generated. If at this stage the board does not provide the correct outputs then potentially the board should be replaced
- check the pump electrical circuit

SERVICING AND MAINTENANCE

Electrical power connections

Reference schematic opposite	Check procedure
Power supply to PWM Controller PCB	Electrically isolate power supply at fused spur switch and remove fuse.
	Earth continuity test (dead test) – to ensure that the appliance is earthed
	Mains voltage test (dead test) - to ensure that the appliance is isolated
	Resistance to earth (dead test) – to ensure that the wiring insulation to the product is intact
	Short circuit test (dead test) – to ensure that no components in the products circuit have a short circuit
	Visually inspect wiring is correct as per fig 4.3
	Connect supply
	Polarity test (live test) - to ensure that the live is connector to the live etc <ul style="list-style-type: none"> • Check 230V ac across L1 to Earth • Check 230V ac across L1 to N • Check for 0 to 15V ac N to earth
	Reference to “Boilerfault finder.com” gives clear instructions to on how to perform these tests. (Menu options 1st. Boiler Fault finder 2nd. Electrical safety checks).

Check inputs to the PWM Controller PCB

Reference schematic opposite	Check procedure
CW temperature sensor	Power off
	Disconnect J18
	Measure and record the resistance across terminals 6 and 13
	Measure the cold water inlet temperature
	Compare the resistance measured with chart “Tasseron NTC 12k thermistor”
	The reading should make sense taking measurement conditions into consideration
HW temperature sensor	Power off
	Disconnect J18
	Measure and record the resistance across terminals 7 and 14
	Measure the Hot water temperature
	Compare the resistance measured with chart “HUBA combined flow sensor and NTC 12k thermistor”
	The reading should make sense taking measurement conditions into consideration
Flow sensor	Power on Sensor requires a 5 VDC power supply
	Open a HW tap and set to a flow rate.
	Measure and record the frequency across terminals 1 and 12
	Compare the frequency measured with chart “flow rate determination”
	The reading should make sense taking measurement conditions into consideration

SERVICING AND MAINTENANCE

Fischer NTC 12k thermistor			Hall combined flow sensor and NTC 60k thermistor			flow rate determination			
Resistance	Temperature		Resistance	Temperature		Hz	l/min	Hz	l/min
10k	70	2.6	10k	40	2.6	20	3.4	95	17.1
30k	-40	1.7	30k	-30	0.8	25	4.4	100	18.0
170k	-30	1.7	47k	-6	0.1	30	5.3	105	19.0
200k	-20	1.8	200k	5	0.1	35	6.2	110	19.9
500k	-10	1.5	100k	23	0.6	40	7.1	115	20.8
361k	0	1.4	165k	24	0.6	45	8.0	120	21.7
200k	10	1.4	100k	25	0.6	50	8.9	125	22.6
500k	20	1.3	65k	26	0.7	55	9.8	130	23.5
100k	30	1.2	40k	27	0.7	60	10.7	135	24.4
200k	30	1.2	25k	28	0.8	65	11.7	140	25.3
500k	40	1.1	15k	30	0.9	70	12.6	145	26.2
100k	50	1	7k	33	0.6	75	13.5	150	27.2
300k	60	0.9	3k	35	0.7	80	14.4	155	28.1
200k	70	1.1	2k	35	0.7	85	15.3	160	29.0
500k	80	1.3	1k	37	0.8	90	16.2	165	29.9
100k	90	1.5	550k	39	0.9				
100k	100	1.8	300k	43	1.1				
			200k	44	1.2				
			100k	47	1.3				
			200k	50	1.5				
			300k	54	1.7				
			200k	59	1.9				
			200k	65	2.3				
			150k	73	3.7				
			100k	85	4.3				

Local on the pump or separate sensors and the cold water inlet temperature sensors		Local on the pump or separate sensors and the cold water inlet temperature sensors	
R-Resistance	Temperature @ 25°C	R-Resistance	Temperature @ 25°C
10k	107.40°C	10k	107.40°C
10k	36.640°C	10k	36.640°C
10k	-40°C	10k	-40°C
10k	107.40°C	10k	107.40°C

Check for presence of overheat link

An overheat link connection should be present in connection Junction 7. If you are fitting a new board the overheat link that is on the board just removed must be retained as the newly supplied board will not have one fitted.

Check outputs from the PWM controller PCB to the pump

PWM pump power	Check 230V ac across Junction 8, L(10) to E(6) and L(10) to N(8) (live test)
	Check for 0-15V ac across Junction 8, N(8) to E(6) (live test)
PWM frequency	Power on the unit
	Set the multi meter to measure the frequency
	Measure the PWM frequency produced by the board between pins 3 on J8 and pin 9 on J8
	This can be between 100Hz – 5000 Hz (1000Hz nominal) (Lab tested figure of 562Hz recorded in steady state conditions).
Duty cycle	Switch your Multimeter to 'duty cycle or %' then it will show a percentage from 0 to 100%.
	This percentage is the command for the pump how fast it should run.
	When you perform a small DHW tapping, the percentage will be low
	When you perform a large DHW tapping, the percentage will be higher
	PWM input signal [%] indications <ul style="list-style-type: none"> • 0-7 Pump stops (Standby) • 7-15 Pump runs at minimum speed (operation) • 12-15 Pump runs at minimum speed (start-up) • 15-95 Pump speed increases linearly from minimum to maximum • > 95 Pump runs at maximum speed

SERVICING AND MAINTENANCE

Check pump electrical circuits

LED	Meaning	Diagnosis	Cause	Remedy
Lights green	Normal running	Pump runs according PWM input	Normal operation	n/a
Blinks red/ green	Abnormal running mode -pump stopped but still functional	The pump has stopped due to external failure Pump restarts by itself after the fault has disappeared	Under voltage $U < 160\text{ V}$ or Over voltage $U > 253\text{ V}$	Check voltage supply $195\text{ V} < U < 253\text{ V}$
			Pump overheating: temperature inside motor too high	Check water and ambient temperature
			Over speed: the pump rotor is driven by an external flow above the maximum allowed value	Ensure that there is no other external flow (other pump running) on system
			Over current: the stator winding is in short circuit due to water	Check for leakage application on application
			Overload of motor: friction due to particles and/or impeller blocked with debris	Check installation water quality, clean system if debris
Blinks red	Pump out of function	Pump stopped (blocked)	Blockage: the pumps is fully blocked due to debris in system	Check for blockage. Turn ON/OFF to reset the pump by unplugging the power supply
			Faulty electronic module and/or faulty motor	If the pumps still blinking red after a power reset then replace the pump
LED off	No power supply	No voltage on electronics	Pump is not connected to power supply	Check cable connection
			LED is damaged	Check if pump is running
			Electronics are damaged	Replace pump

Check plumbing components

CW In line filter	Isolate the CW mains supply at the servicing valve
	Open HW taps to relieve the pressure
	Undo securing nut ensuring that any remaining water is collected
	Remove filter and clean it
	The flow regulator can be checked at the same time by removing the upper pipe section.
Thermal store return check valve + return servicing valve	Isolate both servicing valves
	Drain water from the section between the servicing valves
	Remove the bottom pipe section
	Check for free movement of the check valve incorporated in the body. Remove and replace if the check valve sticks.

SERVICING AND MAINTENANCE

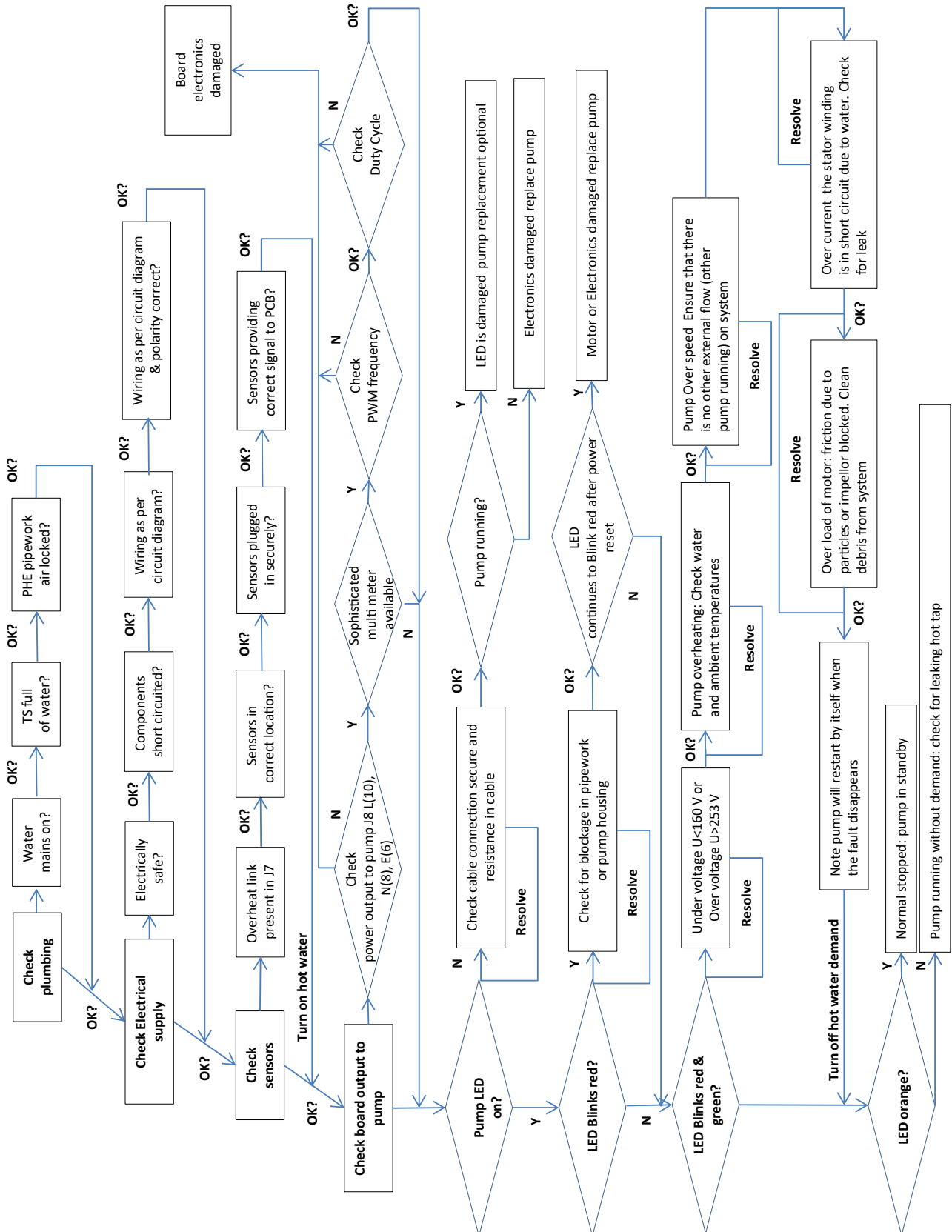

APPENDIX

Water Savings

Water Related Costs Can Be Reduced By Good Plumbing Practice

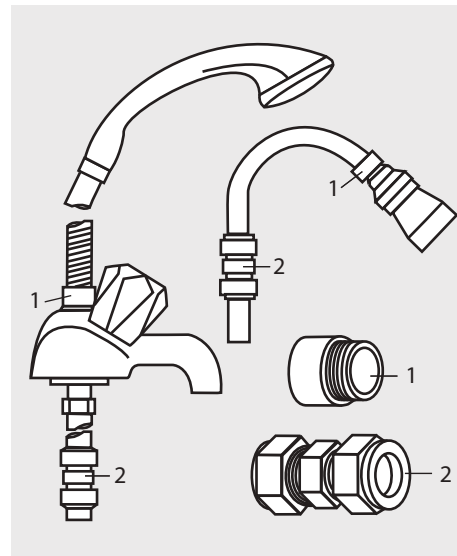
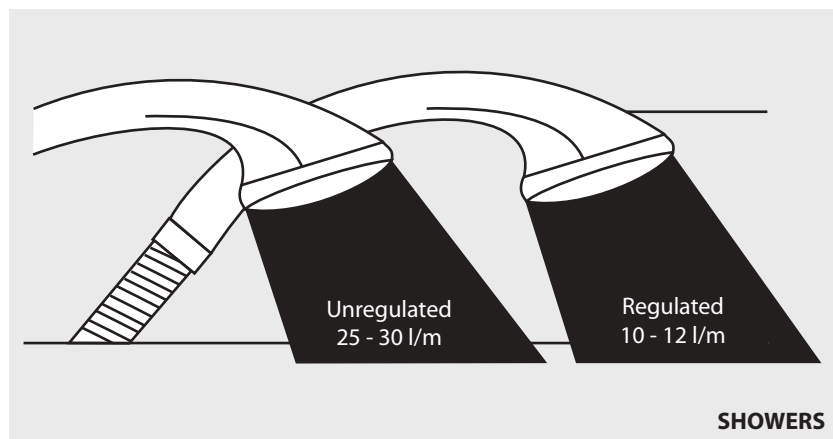
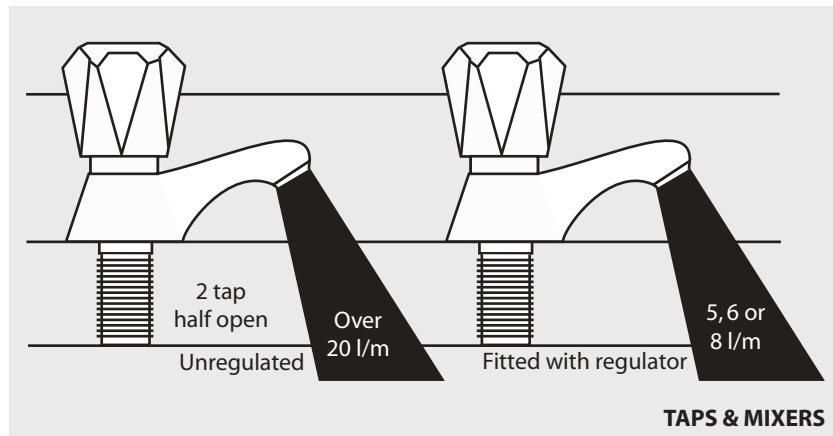

4 Fixing Options For Taps & Mixers

1. MK Range - Combined Regulators & Aerator for screwing onto Taps & Mixers with internal or external threads on their noses. Anti Vandal models also available.
2. MR05-T Range - Internal Regulators. Push-fit into Tap or Mixer seats. Produced in three sizes - 12.5mm (BS1010), 12mm & 10mm, Flangeless models also available for Taps with Low Lift washers.
3. MXF Standard Range - Screw on tail models for Taps & Mixers. Fix onto the tails before fitting the tap connectors. Available in 3/8", 1/2", 3/4" and 1" BSP.
4. Compression Fitting Range - "In Line" regulators housed in 15mm & 22mm CXC Couplers & Isolating Valves. "UKWFBS listed by the Water Research Centre. Isolation valves available for slotted screwdriver operation or with coloured plastic handles. Now available also in plastic bodied push-fit couplers & valves.

Vast quantities of water are needlessly run off to waste due to Taps, Mixers and Showers discharging flow rates far in excess of the rates required for them to perform their duties.

The contrasting flow rates shown on this leaflet clearly illustrate the savings that can be made whilst still providing a good performance.

British made Aquaflow Regulators provide constant flow rates by automatically compensating for supply pressure changes between 1 bar & 10 bars.

To facilitate installation into the wide range of plumbing equipment which is encountered in the U.K, Four Fixing Options are available:-

Options For Showers

1. MXF "DW" Range - For fitting behind Fixed Shower Heads or onto Flexible Hoses for Handshowers (preferably onto the inlet end when lightweight hoses are used).
2. Compression Fitting Range. "In Line" regulators as in Option 4 for Taps & Mixers.

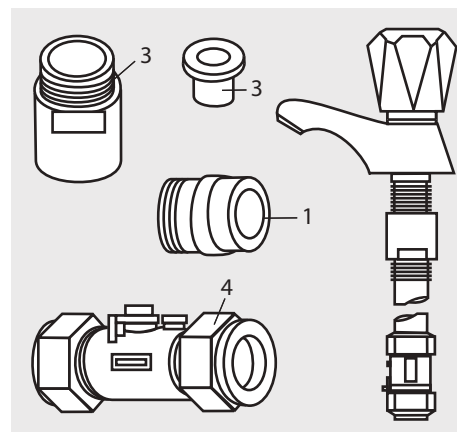

Information by courtesy of

AQUAFLOW REGULATORS LTD

Haywood House, 40 New Road, Stourbridge, West Midlands DY8 1PA
TELEPHONE (01384) 442611 FAX: (01384) 442612



2 Inhibitor (Corrosion & scale protection of primary heating circuit)

On filling the heating system and before the boiler is fired up, it is important to ensure the system water is treated with a suitable corrosion inhibitor, in accordance with the boiler manufacturer's instructions.

Since the concentration of inhibitor present in a system can become diluted, for a number of different reasons, the system should be checked annually and re-treated as required, or after every full or partial drain-down. A water treatment manufacturer's test kit may be used to check the correct concentration of inhibitor in the system.

Where recommended by a boiler manufacturer, a 'physical corrosion protection device' may be fitted in the primary pipework in accordance with the boiler manufacturer's instructions.

The Benchmark checklist should be completed indicating the date and details of any of the above products added and a permanent label should be fixed to the system in a prominent location.

3 Scale protection (Domestic hot water service)

Where a combi boiler and/or a hot water storage vessel is installed in areas where the mains water can exceed 200ppm Total Hardness (as defined by BS 7593: 1993 Table 2) a scale reduction device should be installed, in accordance with the boiler manufacturer's instructions.

The levels of water hardness may be measured using a water hardness test kit.

BUILDING REGULATIONS

Completion of the Benchmark checklist requires that the 'competent person' undertaking the installation and commissioning provide information relating to Cleaning, Inhibitor and Scale Protection. This will demonstrate that the work complies with the requirements of the appropriate Building Regulations.

This Guidance Note is produced on behalf of its members by the Central Heating Information Council. For a full list of members visit www.centralheating.co.uk and for further advice on water treatment contact the following members:

 Culligan  Sentinel  Ferno  Salamander Engineering  Scalemaster

Heating & Hotwater Information Council, 36 Holly Walk, Leamington Spa,
Warwickshire CV32 4LY Tel: 0845 600 2200 Fax: 01926 423284
www.centralheating.co.uk



Benchmark is managed by The Heating & Hotwater Information Council

Gledhill (Building Products) Ltd

AMD. APRIL 2018

CONDITIONS OF SALE & GUARANTEE TERMS

1. Gledhill (Building Products) Ltd ("We" or "Gledhills") only do business upon the Conditions which appear below and no other. Unless we so agree in writing these Conditions shall apply in full to any supply of goods by us to the exclusion of any Conditions or terms sought to be imposed by any purchaser. These Conditions of Sale and Warranty Terms override those which are contained on the Invoice Forms and all Sales are now subject to these Conditions of Sale and Warranty terms only.

2. PRICE

Once an order or call off has been accepted the price will be held for three months **but if delivery is extended beyond that period at the customer's request, then we reserve the right to amend the price when necessary.** The company reviews its pricing annually to adjust for changes in our cost base. We reserve the right to alter prices at any time for severe movements in raw materials (mainly copper and steel). If there is to be a change we will give customers at least **four weeks** notice but **anything delivered** after that date will be at the revised price. An order may not be cancelled or varied after acceptance without the written consent of the company. Such cancellation or variation shall be subject to such reasonable charges as may be appropriate.

3. SPECIFICATION

The goods are supplied in accordance with the Specifications (if any) submitted to the Purchaser and any additions and alterations shall be the subject of an extra charge. Any goods not so specified shall be in accordance with our printed literature or the literature of any of our component suppliers (subject to any modifications made since publication). If we adopt any changes in construction or design of the goods, or in the specification printed in our literature, the Purchaser shall accept the goods so changed in fulfilment of the order.

4. PAYMENT

The buyer shall make payment in full within thirty days from the end of the month in which the invoice is dated. If we receive payment in full on or before the due date we will allow an appropriate settlement discount except where we have quoted a special net price. If payment is not received in full on or before the due date we shall be entitled in addition to the invoice price to:

- (i) payment of a sum equal to any increase in the copper price supplement applicable to the particular goods sold between the date of receipt of order and the date of receipt of payment in full; and
- (ii) interest on any part of the invoice price unpaid after the due date at the rate of 3% per annum over the base rate for the time being of HSBC Bank plc.

5. TIME

We give estimates of delivery dates in good faith and time of delivery is not nor shall be made of the essence of any contract nor shall we be liable for any loss or damage occasioned by delay in delivery.

6. DELIVERY

Standard delivery is free of charge on normal lead times to mainland UK. We reserve the right to make delivery of goods contained in one order by more than one consignment and at different times. Where a period is agreed for delivery and such period is not extended by our Agreement, the Purchaser shall take delivery within that period. If the Purchaser fails to take delivery, we shall be entitled at the Purchaser's risk and expense to store the goods at the Purchaser's premises or elsewhere and to demand payment as if they had been despatched. Off loading at point of delivery shall be the responsibility of and be undertaken by the Purchaser.

7. SHORTAGES OR DAMAGE

Goods must be inspected before signature of delivery note and any damage, shortage or discrepancy noted on the delivery note and the goods returned on the same vehicle. The buyer must also give us immediate written notice of the damage, shortage or discrepancy so that we may prompt investigation.

8. RETURN OF GOODS

Goods may not be returned to the Company except by prior written permission of an authorised officer of the Company and such return shall be subject to payment by the Purchaser of handling and re-stocking charges, transport and all other costs incurred by the Company.

9. COMPANY LIABILITY AND GUARANTEE

9.1. Subject to the terms of these Conditions of Sale and Guarantee Terms Gledhills provide Guarantees in respect of specific products as set out in this clause.

9.2. Each Guarantee is strictly conditional upon the following:-

9.2.1. Complaints must be given to us immediately, before any action is taken, as responsibility cannot be accepted if repairs or renewals are attempted on site without our written approval.

9.2.2. The unit has been installed in accordance with our installation and service instructions and all relevant codes of practice and regulations in force at the time of installation.

9.2.3. All necessary inlet controls and safety valves have been fitted correctly.

9.2.4. The unit has only been used for the storage of potable water supplied from the public mains. The water quality shall be in accordance with European Council Directive 98/83 EC, or revised version at the date of installation, and is not fed with water from a private supply. Particular:

Chloride content:	Max. 200 mg/l
Sulphate content:	Max. 200 mg/l
Combination chloride/sulphate:	Max. 300 mg/l (in total)

9.2.5. Where appropriate the unit has been regularly maintained as detailed in the installation and service instructions

9.2.6. Defects caused by corrosion or scale deposits are not covered by any Guarantee.

9.2.7. Where we agree to rectify any defect we reserve the right to undertake the work on our own premises.

9.2.8. We will not accept any labour charges associated with replacing the unit or parts for any of the following products listed.

9.2.9. If the newly fitted water heater is not in regular use then it must be flushed through with fresh water for at least 15 minutes. Open at least one hot water tap once per week, during a period of at least 4 weeks.

9.3. Guarantees are provided in respect of specified goods supplied by Gledhills as follows:-

(a) Domestic and Commercial Open Vented Cylinders and Tanks.

The storage vessel is guaranteed for ten years and if it proves to be defective either in materials or workmanship, we reserve the right to either repair or supply replacement at our option with the closest substitute in the case of any obsolete product to any address in England, Wales and Scotland (excluding all Scottish Islands).

(b) Domestic Mains Fed Products [Primary Stores]

The storage vessel is guaranteed for five years and if it or any integral pipework as part of the storage vessel assembly proves to be defective either in materials or workmanship, we reserve the right to either repair or supply replacement at our option with the closest substitute in the case of any obsolete product to any address in England, Wales and Scotland (excluding all Scottish Islands).

(c) Unvented Cylinders

Gledhill guarantee the components including controls, valves and electrical parts for two years from the date of purchase. IT SHOULD BE NOTED THAT THE FACTORY FITTED TEMPERATURE AND PRESSURE RELIEF VALVE MUST NOT BE REMOVED OR ALTERED IN ANY WAY OR THE GUARANTEE WILL NOT BE VALID. GLEDHILL WILL NOT BE RESPONSIBLE FOR ANY CONSEQUENTIAL LOSS OR DAMAGE HOWEVER IT IS CAUSED.

The guarantee for the stainless steel vessel is for twenty five years against material defect or manufacturing faults if the original unit is returned to us **AND PROVIDED THAT:**

- (i) It has not been modified, other than by Gledhill.
- (ii) It has not been subjected to wrong or improper use or left uncared for.
- (iii) It has only been used for the storage of potable water supplied from the public mains, max 200mg/litre chloride.
- (iv) It has not been subjected to frost damage.
- (v) The benchmark service record is completed after each annual service.
- (vi) The unit has been serviced annually.
- (vii) Any disinfection has been carried out strictly in accordance with BS6700.

If the stainless steel vessel proves to be defective either in materials or workmanship we reserve the right to either repair or supply replacement at our option with the closest substitute in the case of any obsolete product to any address in England, Wales and Scotland (excluding all Scottish Islands).

ACTION IN THE EVENT OF FAILURE

We will require the return of a cylinder which develops a leak for inspection. If our examination confirms a failure then an appropriate level of credit against the cost of the original cylinder will be issued in line with the terms of our warranty.

Please note:

- Installation must have been carried out by a licensed specialized company (heating contractor or plumber) following the version of installation instructions in force.
- Gledhill or its representative was given the opportunity to check complaints on site immediately after any defect occurred.
- Confirmation exists that the system was commissioned properly and that the system was checked and maintenance was performed annually by a specialised company licensed for this purpose.

(d) Components of our products other than Storage Vessels and Integral Pipework.

We will either extend to the purchaser the same terms of warranty as we are given by the manufacturer of the component or if the manufacturer does not give any warranty, replace free of charge any component which becomes defective within two years after the date of the delivery by us and is returned to us at the purchaser's expense but we shall not meet the cost of removal or shipping or return of the component or any other cost charges or damages incurred by the purchaser.

9.4.

9.4.1. In respect of goods supplied by us and in respect of any installation work carried out by or on our behalf, our entire liability and the purchaser's sole remedies (subject to the Guarantees) shall be as follows:-

(a) We accept liability for death or personal injury to the extent that it results from our negligence or that of our employees

(b) Subject to the other provisions of this clause 9 we accept liability for direct physical damage to tangible property to the extent that such damage is caused by our negligence or that of our employees, agents or subcontractors.

(c) Our total liability to the purchaser over and above any liability to replace under the Guarantees (whether in contract or in tort including negligence) in respect of any one cause of loss or damage claimed to result from any breach of our obligations hereunder, shall be limited to actual money damages which shall not exceed £20,000 provided that such monetary limit shall not apply to any liability on the part of ourselves referred to in paragraph (a) above

(d) Except as provided in paragraph (a) above but otherwise not withstanding any provision herein contained in no event shall we be liable for the following loss or damage howsoever caused and even if foreseeable by us or in our contemplation:-

- (i) economic loss which shall include loss of profits, business revenue, goodwill or anticipated savings

- (ii) damages in respect of special indirect or consequential loss or damage (other than death, personal injury and damage to tangible property)
- (iii) any claim made against the purchaser by any other party (save as expressly provided in paragraph (b) above)
- (e) Except in respect of our liability referred to in paragraph (a) above no claim may be made or action brought (whether in contract or in tort including negligence) by the purchaser in respect of any goods supplied by us more than one year after the date of the invoice for the relevant goods.
- (f) Without prejudice to any other term we shall not be liable for any water damage caused directly or indirectly as a result of any leak or other defect in the goods. We cannot control the conditions of use of the goods or the time or manner or location in which they will be installed and the purchaser agrees to be fully responsible for testing and checking all works which include the goods at all relevant times (up to, including and after commissioning) and for taking all necessary steps to identify any leaks and prevent any damage being caused thereby.
- (g) Nothing in these Conditions shall confer on the purchaser any rights or remedies to which the purchaser would not otherwise be legally entitled

10. LOSS OR INJURY

Notwithstanding any other provision contained herein the purchaser's hereby agree to fully indemnify us against any damages losses costs claims or expenses incurred by us in respect of any claim brought against us by any third party for:-

- (a) any loss injury or damage wholly or partly caused by any goods supplied by us or their use.
- (b) any loss injury or damage wholly or partly caused by the defective installation or substandard workmanship or materials used in the installation of any goods supplied by us.
- (c) any loss injury or damage in any way connected with the performance of this contract.
- (d) any loss resulting from any failure by the purchaser to comply with its obligations under these terms as to install and/or check works correctly.

PROVIDED that this paragraph will not require the purchaser to indemnify us against any liability for our own acts of negligence or those of our employees agents or sub-contractors

FURTHER in the case of goods supplied by us which are re-sold and installed by a third party by the purchaser it will be the sole responsibility of the purchaser to test the goods immediately after their installation to ensure that inter alia they are correctly installed and in proper working order free from leaks and are not likely to cause any loss injury or damage to any person or property.

11. VARIATION OF WARRANTY AND EXCLUSION

Should our warranty and exclusion be unacceptable we are prepared to negotiate for variation in their terms but only on the basis of an increase in the price to allow for any additional liability or risk which may result from the variation. Purchasers are advised to insure against any risk or liability which they may incur and which is not covered by our warranty.

12. ADVICE

Any advice or assistance given by the Company is provided without charge and is in good faith without undertaking, representation or warranty, and we will not accept any liability, whether consequential or compensatory, for advice or assistance given.

13. RISK AND RETENTION OF TITLE

- (a) goods supplied by us shall be at the Purchaser's risk immediately upon delivery to the Purchaser or into custody on the Purchaser's behalf or to the Purchaser's Order. The Purchaser shall effect adequate insurance of the goods against all risks to the full invoice value of the goods, such insurance to be effective from the time of delivery until property in the goods shall pass to the Purchaser as hereinafter provided.
- (b) property in the goods supplied hereunder will pass to the Purchaser when full payment has been made by the Purchaser to us for :-
 - (i) the goods of the subject of this contract.
 - (ii) all other goods the subject to of any other contract between the Purchaser and us which, at the time of payment of the full price of the goods sold under this contract, have been delivered to the Purchaser but not paid for in full.
- (c) until property in the goods supplied hereunder passes to the Purchaser in accordance with paragraph (2) above.
 - (i) the Purchaser shall hold the goods in a fiduciary capacity for us and shall store the same separately from any other goods in the Purchaser's possession and in a manner which enables them to be identified as our goods.
 - (ii) the Purchaser shall immediately return the goods to us should our authorised representative so request. All the necessary incidents associated with a fiduciary relationship shall apply.
- (d) the Purchaser's right to possess the goods shall cease forthwith upon the happening of any of the following events, namely :-
 - (i) if the Purchaser fails to make payment in full for the goods within the time stipulated in clause 4 hereof.
 - (ii) if the Purchaser, not being a company, commits any act of bankruptcy, makes a proposal to his or her creditors for a compromise or does anything which would entitle a petition for a Bankruptcy Order to be presented.
 - (iii) if the Purchaser, being a company, does anything or fails to do anything which would entitle an administrator or an administrative receiver or a receiver to take possession of any assets or which would entitle any person to present a petition for winding up or to apply for an administration order.
- (e) the Purchaser hereby grants to us an irrevocable licence to enter at any time any vehicle or premises owned or occupied by the Purchaser or in the possession of the Purchaser for the purposes of repossessing and recovering any such goods the property in which has remained in us under paragraph (2) above. We shall not be responsible for and the Purchaser will indemnify us against liability in respect of damage caused to any vehicle or premises in such repossession and removal being damaged which it was not reasonably practicable to avoid.
- (f) notwithstanding paragraph (3) hereof and subject to paragraph (7) hereof, the Purchaser shall be permitted to sell the goods to third parties in the normal course of business. In this respect the Purchaser shall act in the capacity of our commission agent and the proceeds of such sale :-
 - (i) shall be held in trust for us in a manner which enables such proceeds to be identified as such, and;
 - (ii) shall not be mixed with other monies nor paid into an overdrawn bank account.

We, as principal, shall remunerate the Purchaser as commission agent a commission depending upon the surplus which the Purchaser can obtain over and above the sum, stipulated in this contract of supply which will satisfy us.
- (g) in the event that the Purchaser shall sell any of the goods pursuant to clause (6) hereof, the Purchaser shall forthwith inform us in writing of such sale and of the identity and address of the third party to whom the goods

have been sold.

- (h) if, before property in the goods passes to the Purchaser under paragraph (2) above the goods are or become affixed to any land or building owned by the Purchaser it is hereby agreed and declared that such affixation shall not have the effect of passing property in the goods to the Purchaser. Furthermore if, before property in the goods shall pass to the Purchaser under paragraph (2) hereof, the goods are or become affixed to any land or building (whether or not owned by the Purchaser), the Purchaser shall:-
 - (i) ensure that the goods are capable of being removed without material injury to such land or building.
 - (ii) take all necessary steps to prevent title to the goods from passing to the landlord of such land or building.
 - (iii) forthwith inform us in writing of such affixation and of the address of the land or building concerned.

The Purchaser warrants to repair and make good any damage caused by the affixation of the goods to or their removal from any land or building and to indemnify us against all loss damage or liability we may incur or sustain as a result of affixation or removal.

 - (i) in the event that, before property in the goods has passed to the Purchaser under paragraph (2) hereof, the goods or any of them are lost, stolen, damaged or destroyed :-
 - (ii) the Purchaser shall forthwith inform us in writing of the fact and circumstances of such loss, theft, damage or destruction.
 - (iii) the Purchaser shall assign to us the benefit of any insurance claim in respect of the goods so lost, stolen, damaged or destroyed.

14. NON-PAYMENT

If the Purchaser shall fail to make full payment for the goods supplied hereunder within the time stipulated in clause 4 hereof or be in default of payment for any other reason then, without prejudice to any of our other rights hereunder, we shall be entitled to stop all deliveries of goods and materials to the Purchaser, including deliveries or further deliveries of goods under this contract. In addition we shall be entitled to terminate all outstanding orders.

15. VALUE ADDED TAX

All prices quoted are exclusive of Value Added Tax which will be charged at the rate ruling at the date of despatch of invoice.

16. TRADE SALES ONLY

We are only prepared to deal with those who are not consumers within the terms of the Unfair Contract Terms Act 1977, the Sale of Goods Act 1979 and the Supply of Goods and Services Act 1982. Accordingly any person who purchases from us shall be deemed to have represented that he is not a consumer by so purchasing.

17. JURISDICTION

The agreement is subject to English law for products delivered in England and Scottish law for products delivered in Scotland and any dispute hereunder shall be settled in accordance therewith dependent upon the location.

18. PRODUCT DEVELOPMENT

Gledhill have a policy of continuous product development and may introduce product modifications from time to time.

MAINS PRESSURE HOT WATER STORAGE SYSTEM COMMISSIONING CHECKLIST

This Commissioning Checklist is to be completed in full by the competent person who commissioned the storage system as a means of demonstrating compliance with the appropriate Building Regulations and then handed to the customer to keep for future reference.

Failure to install and commission this equipment to the manufacturer's instructions may invalidate the warranty but does not affect statutory rights.

Customer name:		Telephone number:	
Address:			
Cylinder Make and Model			
Cylinder Serial Number			
Commissioned by (PRINT NAME):		Registered Operative ID Number	
Company name:		Telephone number:	
Company address:			
		Commissioning date:	
To be completed by the customer on receipt of a Building Regulations Compliance Certificate*:			
Building Regulations Notification Number (if applicable)			
ALL SYSTEMS PRIMARY SETTINGS (indirect heating only)			
Is the primary circuit a sealed or open vented system?		Sealed	Open
What is the maximum primary flow temperature?			°C
ALL SYSTEMS			
What is the incoming static cold water pressure at the inlet to the system?			bar
Has a strainer been cleaned of installation debris (if fitted)?		Yes	No
Is the installation in a hard water area (above 200ppm)?		Yes	No
If yes, has a water scale reducer been fitted?		Yes	No
What type of scale reducer has been fitted?			
What is the hot water thermostat set temperature?			°C
What is the maximum hot water flow rate at set thermostat temperature (measured at high flow outlet)?			l/min
Time and temperature controls have been fitted in compliance with Part L of the Building Regulations?			Yes
Type of control system (if applicable)		Y Plan	S Plan Other
Is the cylinder solar (or other renewable) compatible?		Yes	No
What is the hot water temperature at the nearest outlet?			°C
All appropriate pipes have been insulated up to 1 metre or the point where they become concealed			Yes
UNVENTED SYSTEMS ONLY			
Where is the pressure reducing valve situated (if fitted)?			
What is the pressure reducing valve setting?			bar
Has a combined temperature and pressure relief valve and expansion valve been fitted and discharge tested?		Yes	No
The tundish and discharge pipework have been connected and terminated to Part G of the Building Regulations			Yes
Are all energy sources fitted with a cut out device?		Yes	No
Has the expansion vessel or internal air space been checked?		Yes	No
THERMAL STORES ONLY			
What store temperature is achievable?			°C
What is the maximum hot water temperature?			°C
ALL INSTALLATIONS			
The hot water system complies with the appropriate Building Regulations			Yes
The system has been installed and commissioned in accordance with the manufacturer's instructions			Yes
The system controls have been demonstrated to and understood by the customer			Yes
The manufacturer's literature, including Benchmark Checklist and Service Record, has been explained and left with the customer			Yes
Commissioning Engineer's Signature			
Customer's Signature			
(To confirm satisfactory demonstration and receipt of manufacturer's literature)			

*All installations in England and Wales must be notified to Local Authority Building Control (LABC) either directly or through a Competent Persons Scheme. A Building Regulations Compliance Certificate will then be issued to the customer.



While this Checklist can be used for any installation covered by its description, only appliances manufactured by Scheme Members will be covered by the rules and requirements of the Benchmark Scheme.

SERVICE RECORD

It is recommended that your hot water system is serviced regularly and that the appropriate Service Record is completed.

Service Provider

Before completing the appropriate Service Record below, please ensure you have carried out the service as described in the manufacturer's instructions.

SERVICE 01		Date:	SERVICE 02		Date:
Engineer name:			Engineer name:		
Company name:			Company name:		
Telephone No:			Telephone No:		
Comments:			Comments:		
.....				
.....				
.....				
.....				
Signature			Signature		
SERVICE 03		Date:	SERVICE 04		Date:
Engineer name:			Engineer name:		
Company name:			Company name:		
Telephone No:			Telephone No:		
Comments:			Comments:		
.....				
.....				
.....				
.....				
Signature			Signature		
SERVICE 05		Date:	SERVICE 06		Date:
Engineer name:			Engineer name:		
Company name:			Company name:		
Telephone No:			Telephone No:		
Comments:			Comments:		
.....				
.....				
.....				
.....				
Signature			Signature		
SERVICE 07		Date:	SERVICE 08		Date:
Engineer name:			Engineer name:		
Company name:			Company name:		
Telephone No:			Telephone No:		
Comments:			Comments:		
.....				
.....				
.....				
.....				
Signature			Signature		
SERVICE 09		Date:	SERVICE 10		Date:
Engineer name:			Engineer name:		
Company name:			Company name:		
Telephone No:			Telephone No:		
Comments:			Comments:		
.....				
.....				
.....				
.....				
Signature			Signature		

TO REGISTER

CALL: 08000 420 430

VISIT: WWW.GLEDHILL.NET/UNIT-REGISTRATION

FOR TECHNICAL SUPPORT:

01253 474584

FOR ANNUAL SERVICE AND MAINTENANCE:

0800 3800 129

FOR SPARE PARTS:

01253 474412

OR

WWW.GLEDHILL-SPARES.NET



Gledhill Building Products Limited
Sycamore Estate,
Squires Gate,
Blackpool FY4 3RL

T: 01253 474550
enquiries@gledhill.net

WWW.GLEDHILL.NET



Due to a programme of continuous improvement Gledhill Building Products reserve the right to modify products without prior notice. It is advisable to check the product technical detail by using the latest design and installation manuals available from our technical support team or on our website. It is an offence to copy or adapt this document without consent of the owner.